



# MASTERFLOW

Stainless Steel Vertical Multistage Centrifugal Pump

**MV, MVI, MVN SERIES**

**1, 2, 3, 4, 5, 10, 15, 20,  
32, 45, 64, 90**

**50 Hz**



**tüv**  
CERT  
ISO 9001

**CE**

## Vertical Multistage Centrifugal Pumps

## MARKET SECTORS

CIVIL, AGRICULTURAL, LIGHT INDUSTRY, WATER TREATMENT, HEATING AND AIR CONDITIONING

## MV Series



### MOTOR

- Squirrel cage in short circuit, aluminium casing, enclosed construction with external ventilation
- IP55 protection
- Class F insulation
- Performances according to EN 60034-1
- Standard voltage:
  - Single-phase version: 220-240 V, 50 Hz.
  - Three-phase version: 220-240/380-415 V, 50 Hz for power up to 3 kW, 380-415/660-690 V, 50 Hz for power above 3 kW

- Handling of water, free of suspended solids, in the civil, industrial and agricultural sectors
- Pressure boosting and water supply systems
- Irrigation systems
- Wash systems
- Water treatment plants
- Handling of moderately aggressive liquids, demineralized water, water and glycol, etc.
- Circulation of hot and cold water for heating, cooling and conditioning systems
- Boiler feed application.
- Tested in compliance with ISO 9906-Annex A.
- Direction of rotation: counter clockwise looking at the pump from the top down

## SPECIFICATIONS PUMP

The MV pump is a non-self priming vertical multistage pump coupled to a standard motor.

The liquid end, located between the upper cover and the pump casing, is held in place by tie rods. The pump casing is available with different configurations and connection types.

- Delivery: up to 120 m<sup>3</sup>/h.
- Head: up to 330 m.
- Temperature of pumped liquid:
  - 20°C to 120°C for MV 1, 2, 3, 4, 5 and 10, 15, 20 standard version
  - 20°C to 120°C for MV 32, 45, 64 and 90, standard version

## TYPICAL APPLICATIONS OF MV SERIES PUMPS

### WATER SUPPLY AND PRESSURE BOOSTING

- Pressure boosting in buildings, hotels, residential complexes
- Pressure booster stations, supply of water networks
- Booster packages

### WATER TREATMENT

- Ultrafiltration systems
- Reverse osmosis systems
- Water softeners and de-mineralization
- Distillation systems
- Filtration

### LIGHT INDUSTRY

- Washing and cleaning plants (washing and degreasing of mechanical parts, car and truck wash tunnels, washing of electronic industry circuits)
- Commercial washers
- Fire fighting system pumps
- Jockey pump for fire fighting system

### IRRIGATION AND AGRICULTURE

- Greenhouses
- Humidifiers
- Sprinkler irrigation

### HEATING, VENTILATION AND AIR CONDITIONING (HVAC)

- Cooling towers and systems
- Temperature control systems
- Refrigerators
- Induction heating
- Heat exchangers
- Boilers
- Water recirculation and heating

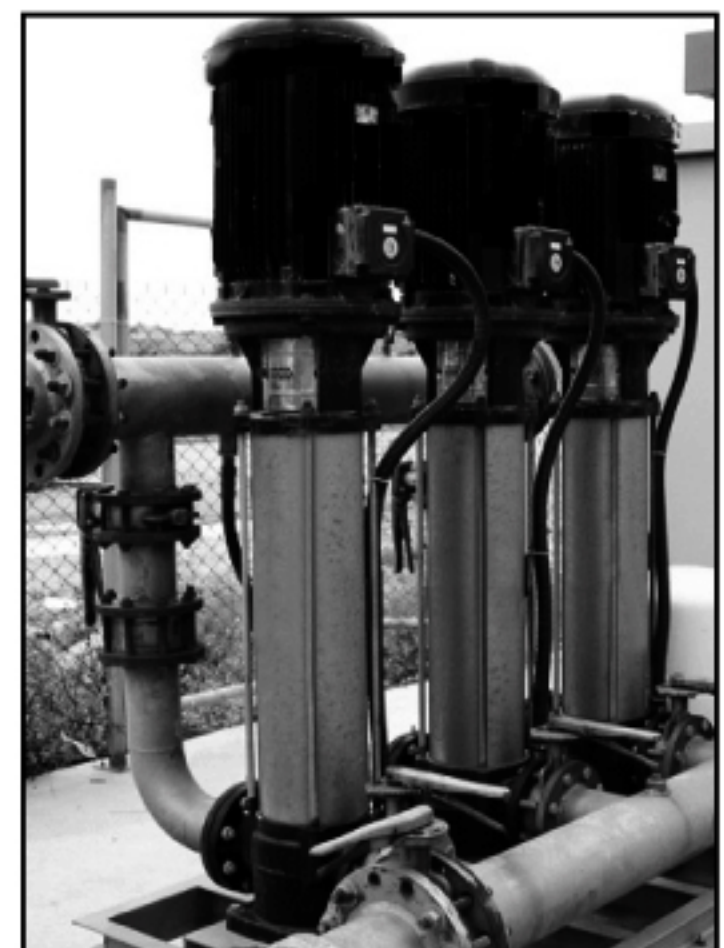
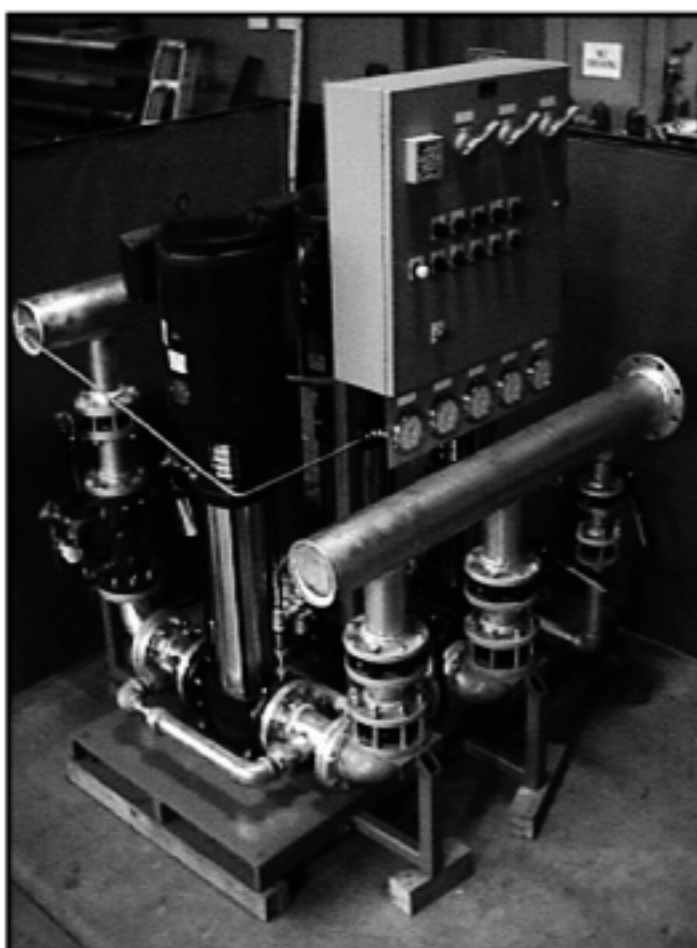
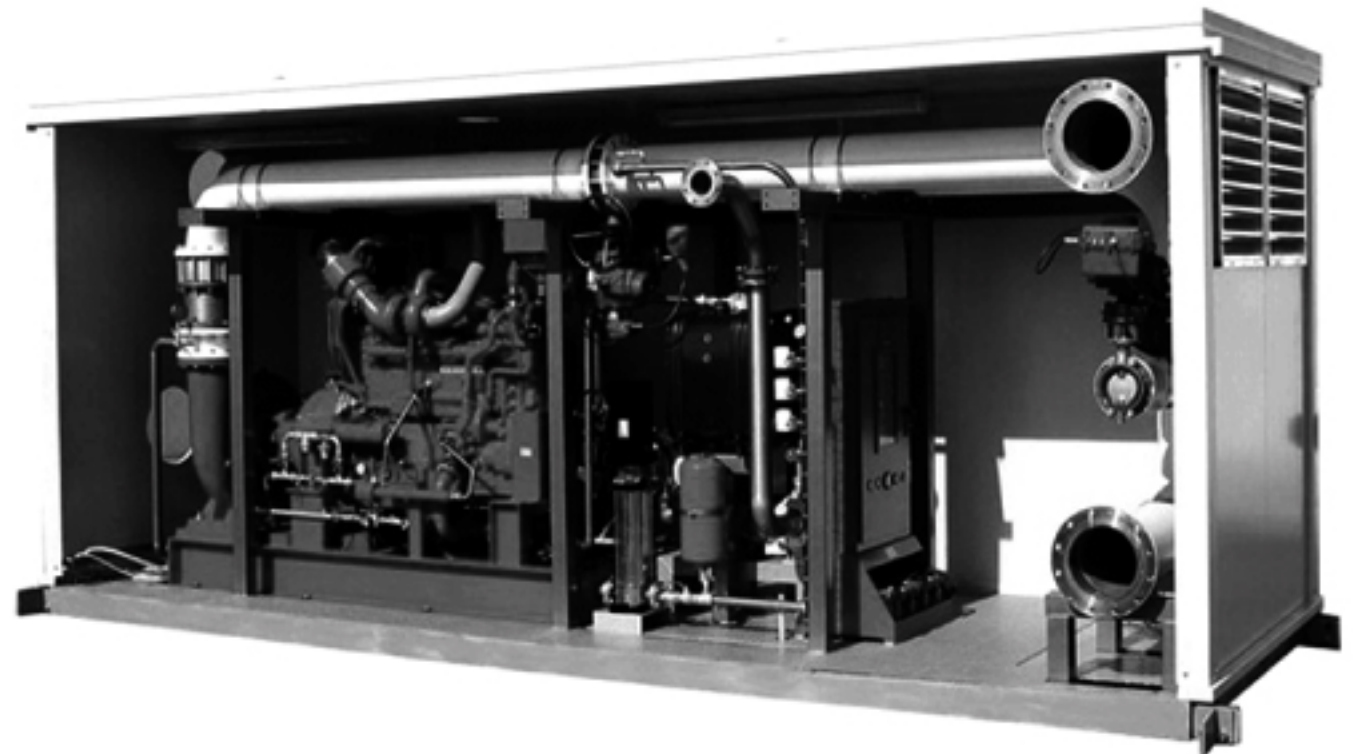

## Construction

**MV 1, 2, 3, 4, 5, 10, 15 and 20**

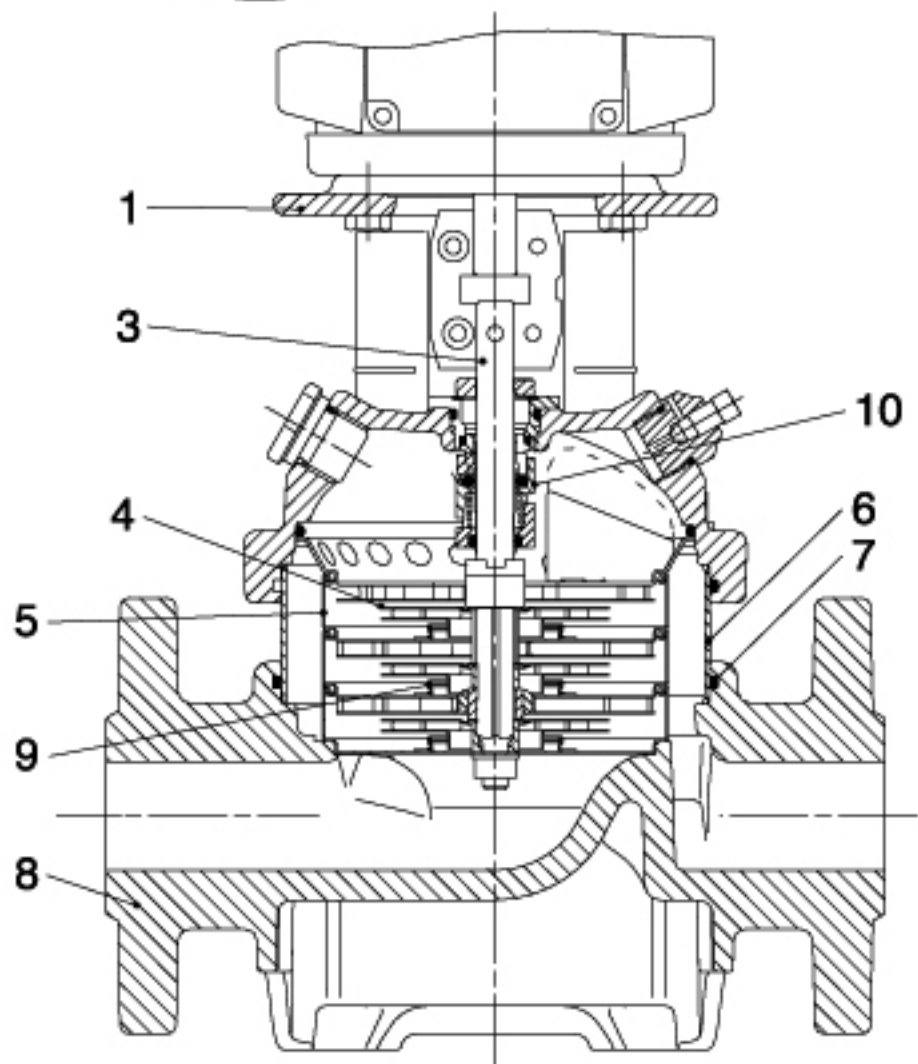
**Sectional drawing**

**Materials: MV**

Pos.	Designation	Materials	AISI/ASTM
1	Pump head	Cast iron EN-GJL-200	ASTM 25B
3	Shaft	Stainless steel	AISI 316 AISI 431
4	Impeller	Stainless steel	AISI 304
5	Chamber	Stainless steel	AISI 304
6	Outer sleeve	Stainless steel	AISI 304
7	O-ring for outer sleeve	EPDM or FKM	
8	Base	Cast iron EN-GJL-200	ASTM 25B
9	Neck ring	PTFE	
10	Shaft seal		
	Rubber parts	EPDM or FKM	

- 1) Stainless steel available on request.  
 2) MVI, MVN 1, 3, 5  
 3) MVI, MVN 10, 15, 20

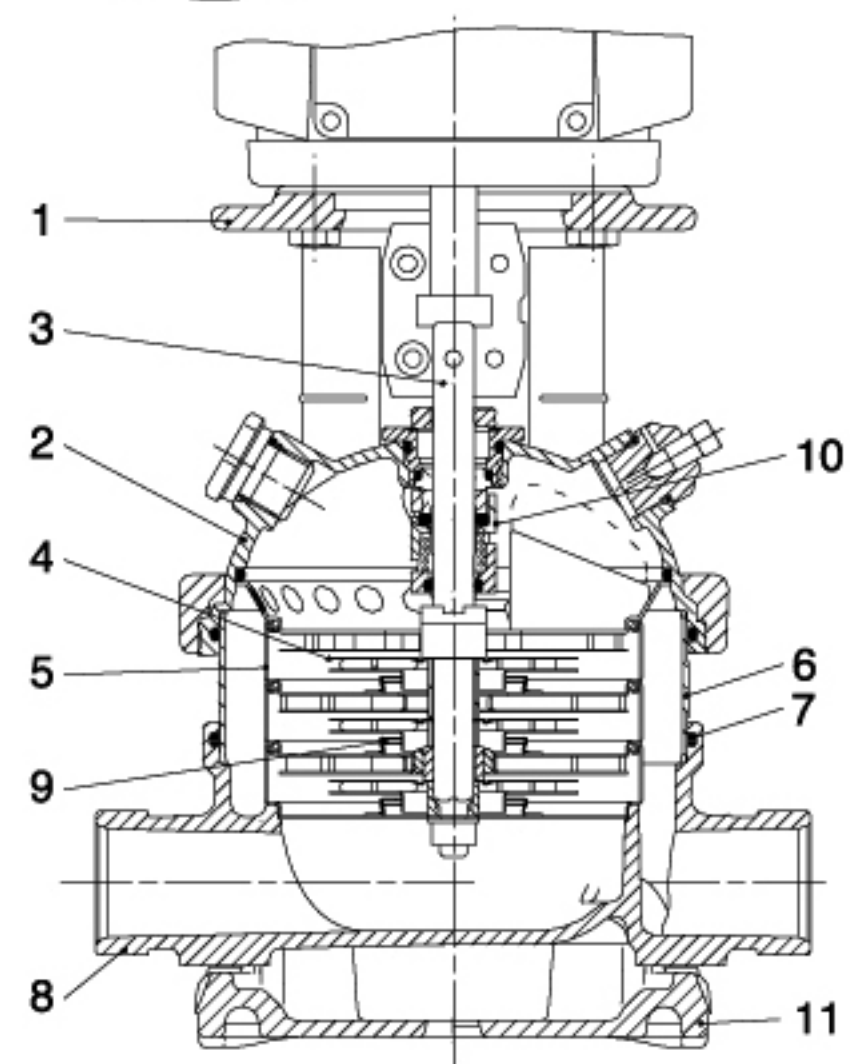
**MVI, MVN 1, 2, 3, 4, 5, 10, 15 and 20**

**Sectional drawing**

**Materials: MVI, MVN**

Pos.	Designation	Materials	AISI/ASTM
1	Pump head	Cast iron EN-GJL-200 <sup>1)</sup>	ASTM 25B
2	Pump head cover	Stainless steel	CF 8M eq. to AISI 316
3	Shaft	Stainless steel	AISI 316 AISI 329
8	Base	Stainless steel	CF 8M eq. to AISI 316
9	Neck ring	PTFE	
10	Shaft seal	Cartridge type	
11	Base plate	Cast iron EN-GJL-200 <sup>1)</sup>	ASTM 25B
	Rubber parts	EPDM or FKM	
<b>MVI</b>			
4	Impeller	Stainless steel	AISI 304
5	Chamber	Stainless steel	AISI 304
6	Outer sleeve	Stainless steel	AISI 304
7	O-ring for outer sleeve	EPDM or FKM	
<b>MVN</b>			
4	Impeller	Stainless steel	AISI 316
5	Chamber	Stainless steel	AISI 316
6	Outer sleeve	Stainless steel	AISI 316
7	O-ring for outer sleeve	EPDM or FKM	

## Construction

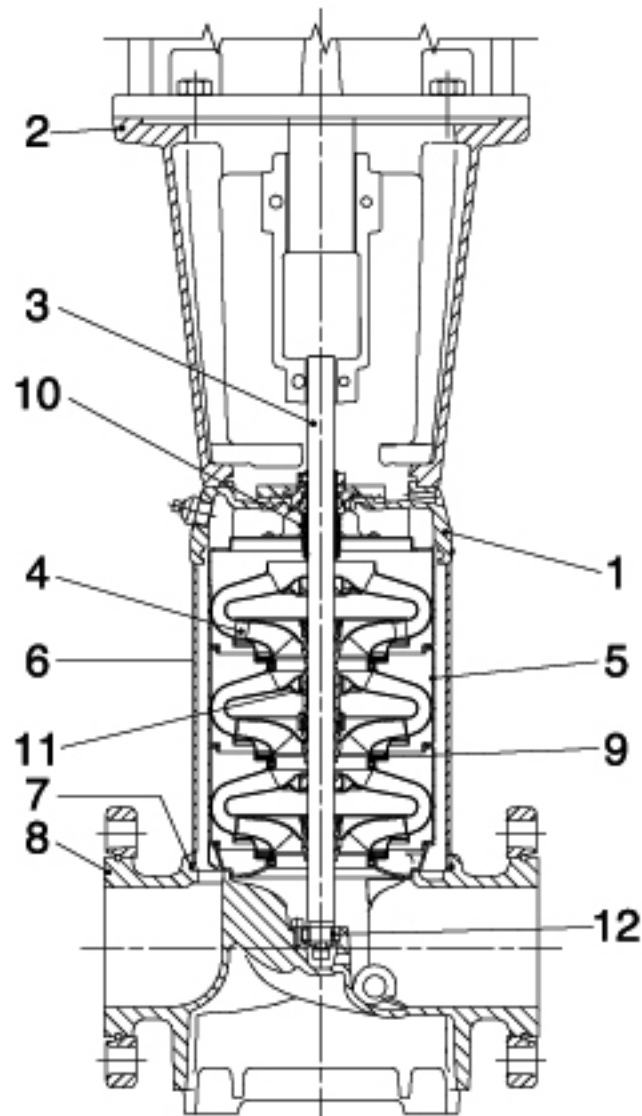
**MV 32, 45, 64 and 90**

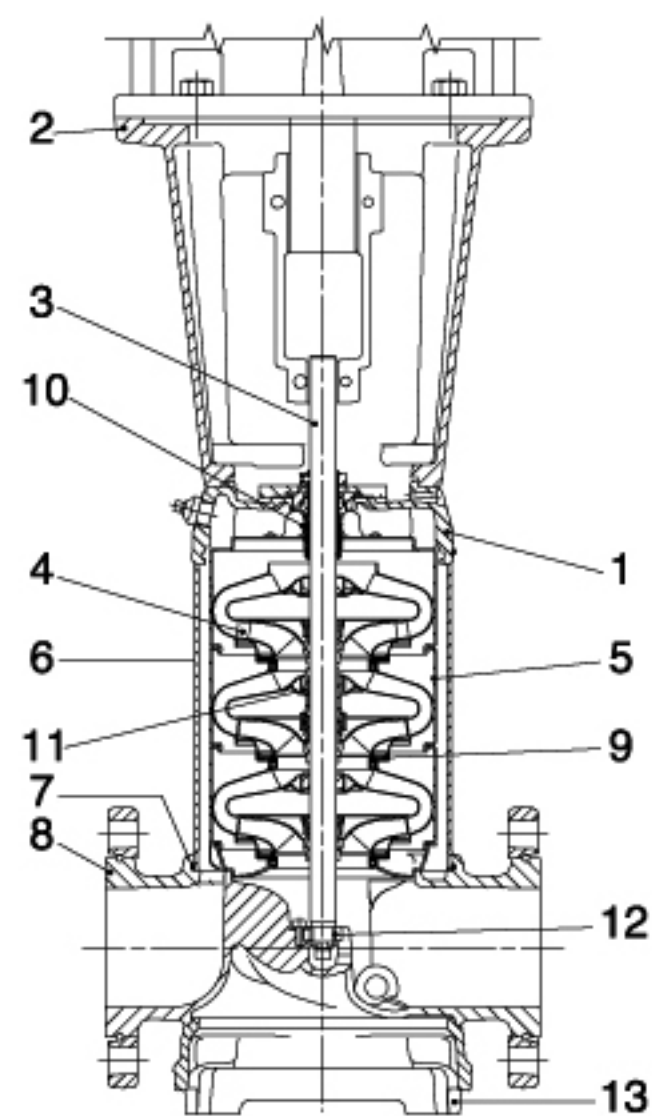
**Sectional drawing**

**MVN 32, 45, 64 and 90**

**Sectional drawing**

**Materials: MV**

Pos.	Designation	Materials	AISI/ASTM
1	Pump head	Cast iron EN-GJS-500-7	ASTM 80-55-06
2	Motor stool	Cast iron EN-GJL-200	ASTM 25B
3	Shaft	Stainless steel	AISI 431
4	Impeller	Stainless steel	AISI 304
5	Chamber	Stainless steel	AISI 304
6	Outer sleeve	Stainless steel	AISI 304
7	O-ring for outer sleeve	EPDM or FKM	
8	Base	Cast iron EN-GJS-500-7	ASTM 80-55-06
9	Neck ring	Carbon-graphite filled PTFE	
10	Shaft seal		
11	Bearing ring	Bronze	
12	Bottom bear- ing ring	Tungsten carbide/ Tungsten carbide	
	Rubber parts	EPDM or FKM	

**Materials: MVN**

Pos.	Designation	Materials	AISI/ASTM
1	Pump head	Stainless steel	CF 8M eq. to AISI 316
2	Motor stool	Cast iron EN-GJL-200 1)	ASTM 25B
3	Shaft	Stainless steel	
4	Impeller	Stainless steel	AISI 316
5	Chamber	Stainless steel	AISI 316
6	Outer sleeve	Stainless steel	AISI 316
7	O-ring for outer sleeve	EPDM or FKM	
8	Base	Stainless steel	CF 8M eq. to AISI 316
9	Neck ring	Carbon-graphite filled PTFE	
10	Shaft seal		
11	Bearing ring	Carbon-graphite filled PTFE	
12	Bottom bear- ing ring	Tungsten car- bide/Tungsten carbide	
13	Base plate	Cast iron EN-GJS-500-7 <sup>1)</sup>	ASTM 88-55-06
	Rubber parts	EPDM or FKM	

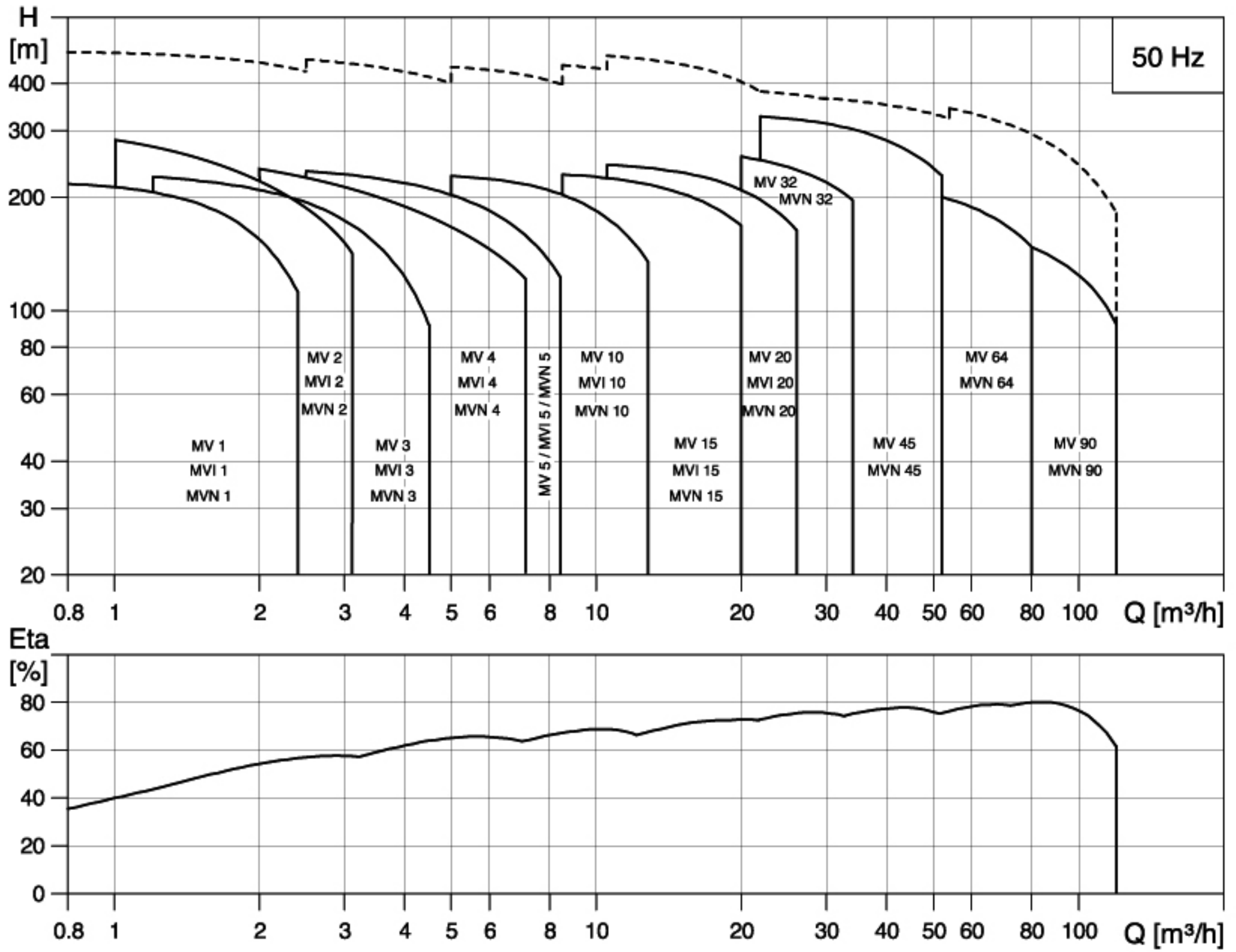
1) Stainless steel available on request.

**Performance range - MV, MVI, MVN**

**CHARACTERISTICS OF MV 1, 2, 3, 4, 5, 10, 15, 20, 32, 45, 64, 90 SERIES**

- Vertical multistage centrifugal pump. All metal parts in contact with the pumped liquid are made of stainless steel.
- The following versions are available:
  - I: round flanges, in-line delivery and suction ports, AISI 304
  - N: round flanges, in-line delivery and suction ports, AISI 316
- Seal housing chamber designed to prevent the accumulation of air in the critical area next to the mechanical seal
- Mechanical seal according to EN 12756 (ex DIN 24960) and ISO 3069
- Versions with round flanges that can be coupled to counter-flanges, according to EN 1092
- Round counter-flanges made of stainless steel are standard supply for the N version
- Easy maintenance. No special tools required for assembly or disassembly
- Materials are suitable for handling potable water (WRAS certified)
- Standard version for temperatures ranging from -20°C to + 120°C

**CHARACTERISTICS OF MV 1, 2, 3, 4, 5, 10, 15, 20, 32, 45, 64, 90 SERIES**

MODEL	1	2	3	4	5	10
Flow at max efficiency (m <sup>3</sup> /h)	1.7	2.2	2.8	5	6	10
Flow range (m <sup>3</sup> /h)	0.7-2.4	1-3.5	1.2-4.5	2-8	2.5-8.4	5-13
Maximum pressure ( bar )	22	26	24	22	24	22
Motor power ( kW )	0.37-2.2	0.37-3	0.37-3	0.37-4	0.37-5.5	0.37-7.5
Max efficiency ( % ) of pump	45	48	56	59	65	70
Standard temperature ( °C )	-20 up to 120 °C					

MODEL	15	20	32	45	64	90
Flow at max efficiency (m <sup>3</sup> /h)	20	22	28	45	65	80
Flow range (m <sup>3</sup> /h)	8.5-23.5	10.5-29	14-40	20-56	30-85	40-120
Maximum pressure ( bar )	23	25	28	26	20	20
Motor power ( kW )	1.1-15	1.1-18.5	1.5-30	3-45	4-45	5.5-45
Max efficiency ( % ) of pump	71	71	77	78	80	81
Standard temperature ( °C )	-20 up to 120 °C					

## Pumped liquids

Thin, non-explosive liquids, not containing solid particles or fibres. The liquid must not chemically attack the pump materials.

When pumping liquids with a density and/or viscosity higher than that of water, oversized motors must be used, if required.

Whether a pump is suitable for a particular liquid depends on a number of factors of which the most important are the chloride content, pH value, temperature and content of chemicals, oils, etc.

Please note that aggressive liquids (e.g. sea water and some acids) may attack or dissolve the protective oxide film of the stainless steel and thus cause corrosion.

The MV, MVI, MVN pump types are suitable for the following liquids:

### MV, MVI

- Non-corrosive liquids.

For liquid transfer, circulation and pressure boosting of cold or hot clean water.

### MVN

- Industrial liquids.

In systems where all parts in contact with the liquid must be made of high-grade stainless steel.

## List of pumped liquids

A number of typical liquids are listed below.

Other pump versions may be applicable, but those stated in the list are considered to be the best choices.

The table is intended as a general guide only, and cannot replace actual testing of the pumped liquids and pump materials under specific working conditions.

The list should, however, be applied with some caution as factors such as

- concentration of the pumped liquid,
- liquid temperature or
- pressure.

may affect the chemical resistance of a specific pump version.

Safety precautions must be made when pumping dangerous liquids.

### Notes

<b>D</b>	Often with additives.
<b>E</b>	Density and/or viscosity differ from that of water. Allow for this when calculating motor output and pump performance.
<b>F</b>	Pump selection depends on many factors.
<b>H</b>	Risk of chrySTALLIZATION/precipitation in shaft seal.
<b>1</b>	The pumped liquid highly inflammable.
<b>2</b>	The pumped liquid is combustible.
<b>3</b>	Insoluble in water.
<b>4</b>	Low self-ignition point.

Pumped liquid	Note	Liquid concentration, liquid temperature	MV, MVI			MVN		
			1, 2, 3, 4, 5	10, 15, 20	32, 45, 64, 90	1, 2, 3, 4, 5	10, 15, 20	32, 45, 64, 90
Acetic acid, CH <sub>3</sub> COOH	-	5%, +20°C	-	-	-	HQQE	HQQE	HQQE
Acetone, CH <sub>3</sub> COCH <sub>3</sub>	1, F	100%, +20°C	-	-	-	HQQE	HQQE	HQQE
Alkaline degreasing agent	D, F	-	HQQE	HQQE	HQQE	-	-	-
Ammonium bicarbonate, NH <sub>4</sub> HCO <sub>3</sub>	E	20%, +30°C	-	-	-	HQQE	HQQE	HQQE
Ammonium hydroxide, NH <sub>4</sub> OH	-	20%, +40°C	HQQE	HQQE	HQQE	-	-	-
Aviation fuel	1, 3, 4, F	100%, +20°C	HQBV	HQBV	HQBV	-	-	-
Benzoic acid, C <sub>6</sub> H <sub>5</sub> COOH	H	0.5%, +20°C	-	-	-	HQQV	HQQV	HQQV
Boiler water	-	<+120°C	HQQE	HQQE	HQQE	-	-	-
	F	+120°C - +180°C	-	-	-	-	-	-
Calcareous water	-	<+90°C	HQQE	HQQE	HQQE	-	-	-
Calcium acetate (as coolant with inhibitor) Ca(CH <sub>3</sub> COO) <sub>2</sub>	D, E	30%, +50°C	HQQE	HQQE	HQQE	-	-	-
Calcium hydroxide, Ca(OH) <sub>2</sub>	E	Saturated solution, +50°C	HQQE	HQQE	HQQE	-	-	-
Chloride-containing water	F	<+30°C, max. 500 ppm	-	-	-	HQQE	HQQE	HQQE
Chromic acid, H <sub>2</sub> CrO <sub>4</sub>	H	1%, +20°C	-	-	-	HQQV	HQQV	HQQV

Pumped liquid	Note	Liquid concentration, liquid temperature	MV, MVI			MVN		
			1, 2, 3, 4, 5	10, 15, 20	32, 45, 64, 90	1, 2, 3, 4, 5	10, 15, 20	32, 45, 64, 90
Citric acid, $\text{HOC}(\text{CH}_2\text{CO}_2\text{H})_2\text{COOH}$	H	5%, +40°C	-	-	-	HQQE	HQQE	HQQE
Completely desalinated water (demineralized water)	-	+120°C	-	-	-	HQQE	HQQE	HQQE
Condensate	-	120°C	HQQE	HQQE	HQQE	-	-	-
Copper sulfate, $\text{CuSO}_4$	E	10%, +50°C	-	-	-	HQQE	HQQE	HQQE
Corn oil	D, E, 3	100%, +80°C	HQQV	HQQV	HQQV	-	-	-
Diesel oil	2, 3, 4, F	100%, +20°C	HQBv	HQBv	HQBv	-	-	-
Domestic hot water (potable water)	-	<+120°C	HQQE	HQQE	HQQE	-	-	-
Ethanol (ethyl alcohol), $\text{C}_2\text{H}_5\text{OH}$	1, F	100%, +20°C	HQQE	HQQE	HQQE	-	-	-
Ethylene glycol, $\text{HOCH}_2\text{CH}_2\text{OH}$	D, E	50%, +50°C	HQQE	HQQE	HQQE	-	-	-
Formic acid, $\text{HCOOH}$	-	5%, +20°C	-	-	-	HQQE	HQQE	HQQE
Glycerine (glycerol), $\text{OHCH}_2\text{CH}(\text{OH})\text{CH}_2\text{OH}$	D, E	50%, +50°C	HQQE	HQQE	HQQE	-	-	-
Hydraulic oil (mineral)	E, 2, 3	100%, +100°C	HQQV	HQQV	HQQV	-	-	-
Hydraulic oil (synthetic)	E, 2, 3	100%, +100°C	HQQV	HQQV	HQQV	-	-	-
Isopropyl alcohol, $\text{CH}_3\text{CHOHCH}_3$	1, F	100%, +20°C	HQQE	HQQE	HQQE	-	-	-
Lactic acid, $\text{CH}_3\text{CH}(\text{OH})\text{COOH}$	E, H	10%, +20°C	-	-	-	HQQV	HQQV	HQQV
Linoleic acid, $\text{C}_{17}\text{H}_{31}\text{COOH}$	E, 3	100%, +20°C	HQQV	HQQV	HQQV	-	-	-
Methanol (methyl alcohol), $\text{CH}_3\text{OH}$	1, F	100%, +20°C	HQQE	HQQE	HQQE	-	-	-
Motor oil	E, 2, 3	100%, +80°C	HQQV	HQQV	HQQV	-	-	-
Naphthalene, $\text{C}_{10}\text{H}_8$	E, H	100%, +80°C	HQQV	HQQV	HQQV	-	-	-
Nitric acid, $\text{HNO}_3$	F	1%, +20°C	-	-	-	HQQE	HQQE	HQQE
Oil-containing water	-	<+100°C	HQQV	HQQV	HQQV	-	-	-
Olive oil	D, E, 3	100%, +80°C	HQQV	HQQV	HQQV	-	-	-
Oxalic acid, $(\text{COOH})_2$	H	1%, +20°C	-	-	-	HQQE	HQQE	HQQE
Ozone-containing water, $(\text{O}_3)$	-	<+100°C	-	-	-	HQQE	HQQE	HQQE
Peanut oil	D, E, 3	100%, +80°C	HQQV	HQQV	HQQV	-	-	-
Petrol	1, 3, 4, F	100%, +20°C	HQBv	HQBv	HQBv	-	-	-
Phosphoric acid, $\text{H}_3\text{PO}_4$	E	20%, +20°C	-	-	-	HQQE	HQQE	HQQE
Propanol, $\text{C}_3\text{H}_7\text{OH}$	1, F	100%, +20°C	HQQE	HQQE	HQQE	-	-	-
Propylene glycol, $\text{CH}_3\text{CH}(\text{OH})\text{CH}_2\text{OH}$	D, E	50%, +90°C	HQQE	HQQE	HQQE	-	-	-
Potassium carbonate, $\text{K}_2\text{CO}_3$	E	20%, +50°C	HQQE	HQQE	HQQE	-	-	-
Potassium formate (as coolant with inhibitor), $\text{KOOCH}$	D, E	30%, +50°C	HQQE	HQQE	HQQE	-	-	-
Potassium hydroxide, $\text{KOH}$	E	20%, +50°C	-	-	-	HQQE	HQQE	HQQE
Potassium permanganate, $\text{KMnO}_4$	-	5%, +20°C	-	-	-	HQQE	HQQE	HQQE
Rape seed oil	D, E, 3	100%, +80°C	HQQV	HQQV	HQQV	-	-	-
Salicylic acid, $\text{C}_6\text{H}_4(\text{OH})\text{COOH}$	H	0.1%, +20°C	-	-	-	HQQE	HQQE	HQQE
Silicone oil	E, 3	100%	HQQV	HQQV	HQQV	-	-	-
Sodium bicarbonate, $\text{NaHCO}_3$	E	10%, +60°C	-	-	-	HQQE	HQQE	HQQE
Sodium chloride (as coolant), $\text{NaCl}$	D, E	30%, <+5°C, pH>8	HQQE	HQQE	HQQE	-	-	-
Sodium hydroxide, $\text{NaOH}$	E	20%, +50°C	-	-	-	HQQE	HQQE	HQQE
Sodium hypochlorite, $\text{NaOF}$	0.1%, +20°C	-	-	HQQV	HQQV	HQQV	-	-
Sodium nitrate, $\text{NaNO}_3$	E	10%, +60°C	-	-	-	HQQE	HQQE	HQQE
Sodium phosphate, $\text{Na}_3\text{PO}_4$	E, H	10%, +60°C	-	-	-	HQQE	HQQE	HQQE
Sodium sulfate, $\text{Na}_2\text{SO}_4$	E, H	10%, +60°C	-	-	-	HQQE	HQQE	HQQE
Softened water	-	<+120°C	-	-	-	HQQE	HQQE	HQQE
Soya oil	D, E, 3	100%, +80°C	HQQV	HQQV	HQQV	-	-	-
Sulfuric acid, $\text{H}_2\text{SO}_4$	F	1%, +20°C	-	-	-	HQQV	HQQV	HQQV
Sulfurous acid, $\text{H}_2\text{SO}_3$	-	1%, +20°C	-	-	-	HQQE	HQQE	HQQE
Unsalted swimming pool water	-	Approx. 2 ppm free chlorine ( $\text{Cl}_2$ )	HQQE	HQQE	HQQE	-	-	-

### Minimum inlet pressure - NPSH

Calculation of the inlet pressure "H" is recommended when

- the liquid temperature is high,
- the flow is significantly higher than the rated flow,
- water is drawn from depths,
- water is drawn through long pipes,
- inlet conditions are poor.

To avoid cavitation, make sure that there is a minimum pressure on the suction side of the pump. The maximum suction lift "H" in metres head can be calculated as follows:

$$H = p_b \times 10.2 - \text{NPSH} - H_f - H_v - H_s$$

$p_b$  = Barometric pressure in bar.

(Barometric pressure can be set to 1 bar).

In closed systems,  $p_b$  indicates the system pressure in bar.

NPSH = Net Positive Suction Head in metres head.

(To be read from the NPSH curve at the highest flow the pump will be delivering).

$H_f$  = Friction loss in suction pipe in metres head.  
(At the highest flow the pump will be delivering.)

$H_v$  = Vapour pressure in metres head.  
(To be read from the vapour pressure scale. "H<sub>v</sub>" depends on the liquid temperature "T<sub>m</sub>").

$H_s$  = Safety margin = minimum 0.5 metres head.

If the "H" calculated is positive, the pump can operate at a suction lift of maximum "H" metres head.

If the "H" calculated is negative, an inlet pressure of minimum "H" metres head is required.

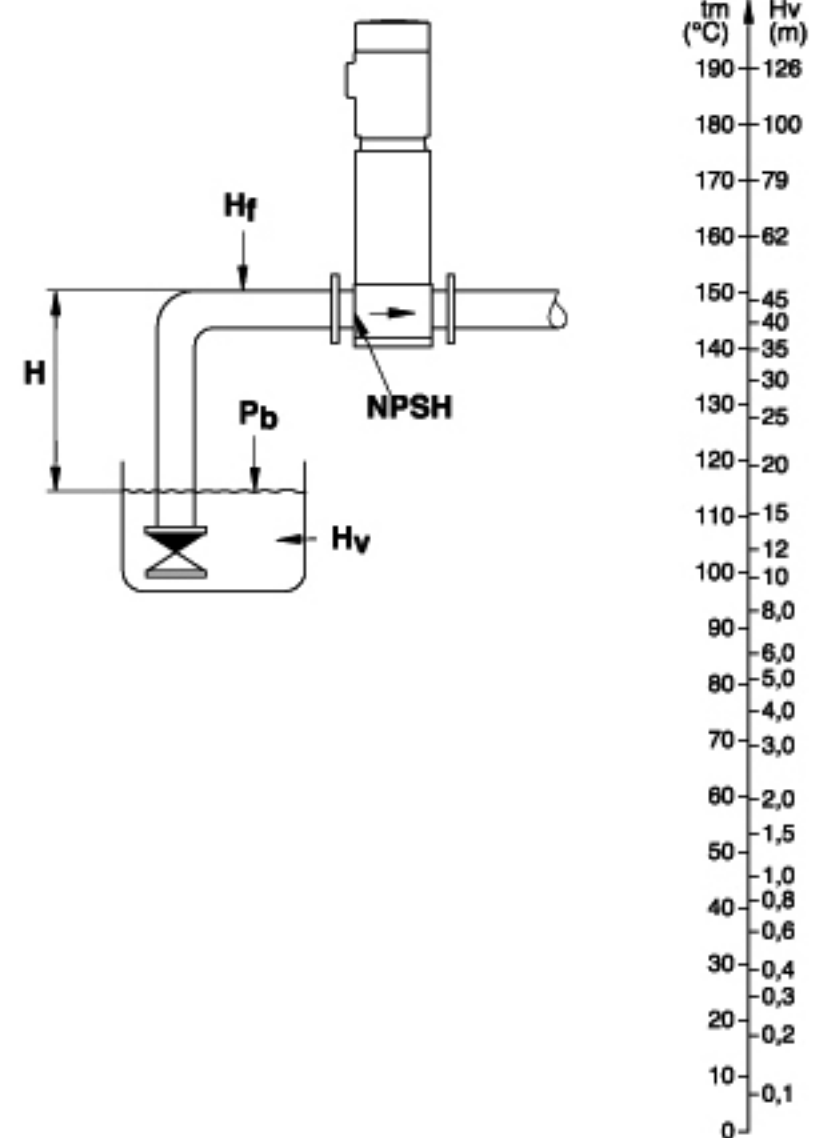

**Fig. 25** Minimum inlet pressure - NPSH

**Note:** In order to avoid cavitation **never** select a pump with a duty point too far to the right on the NPSH curve.

Always check the NPSH value of the pump at the highest possible flow.

## How to read the curve charts

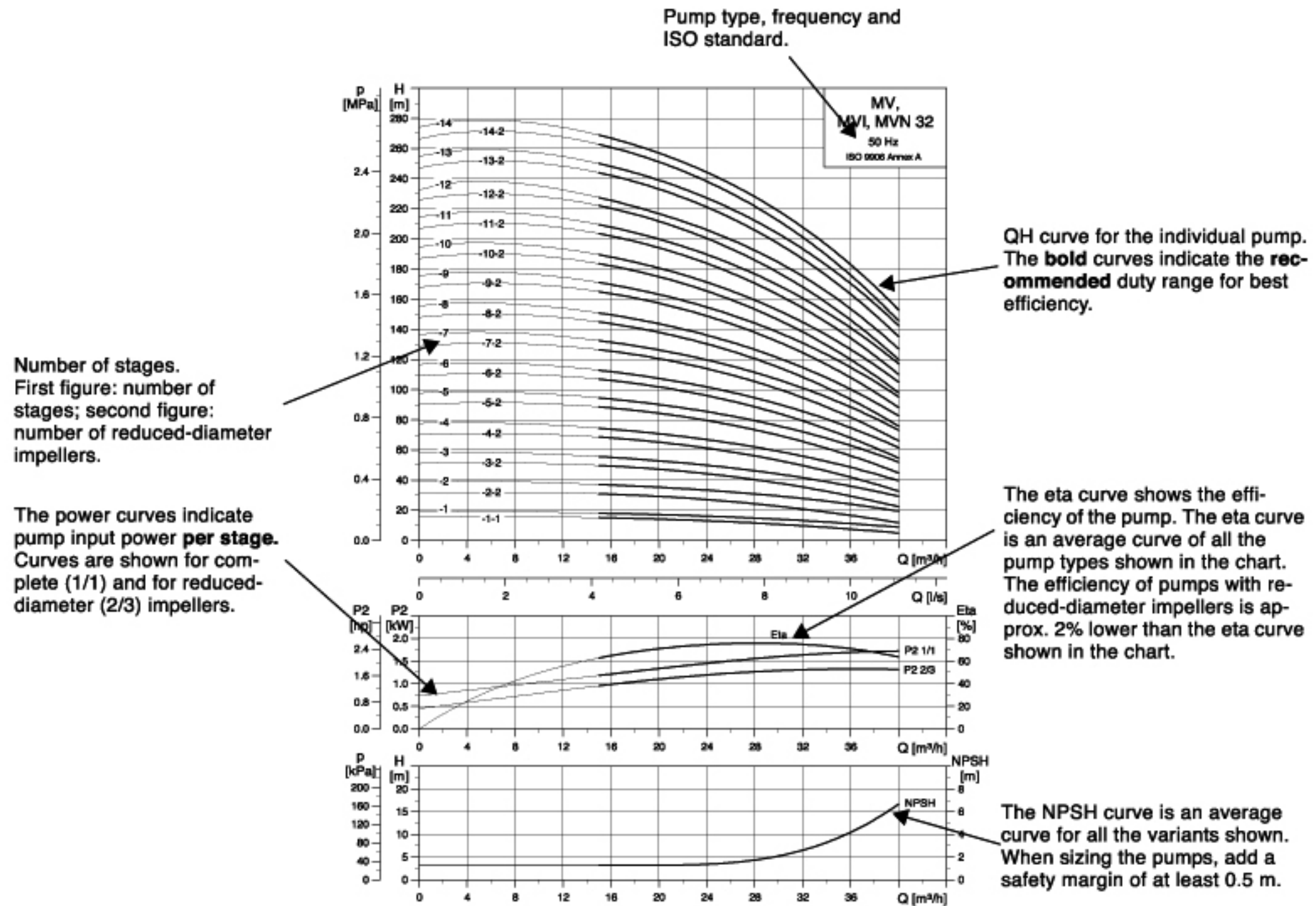

Fig. 26 How to read the curve charts

## Guidelines to performance curves

The guidelines below apply to the curves shown on the following pages:

- Tolerances to ISO 9906, Annex A, if indicated.
- The motors used for the measurements are standard motors designed for MV pumps.
- Measurements have been made with airless water at a temperature of 20°C.
- The curves apply to a kinematic viscosity of  $\nu = 1 \text{ mm}^2/\text{s}$  (1 cSt).
- Due to the risk of overheating, the pumps should not be used at a flow below the minimum flow rate.

The curve below shows the minimum flow rate as a percentage of the nominal flow rate in relation to the liquid temperature. The dotted line shows a MV pump fitted with an air-cooled top assembly.

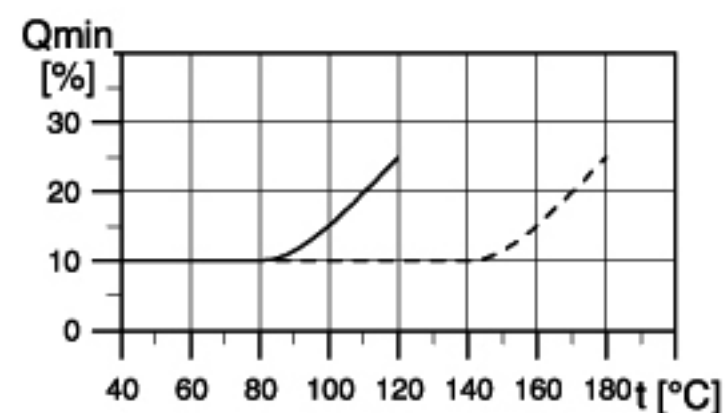
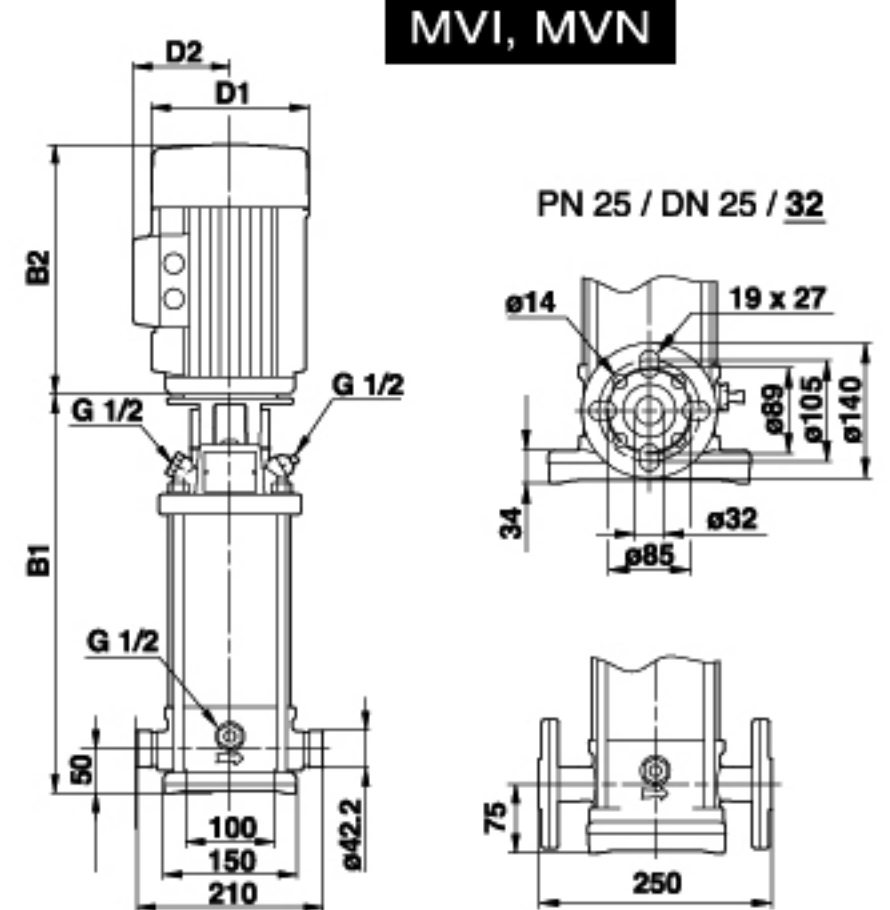
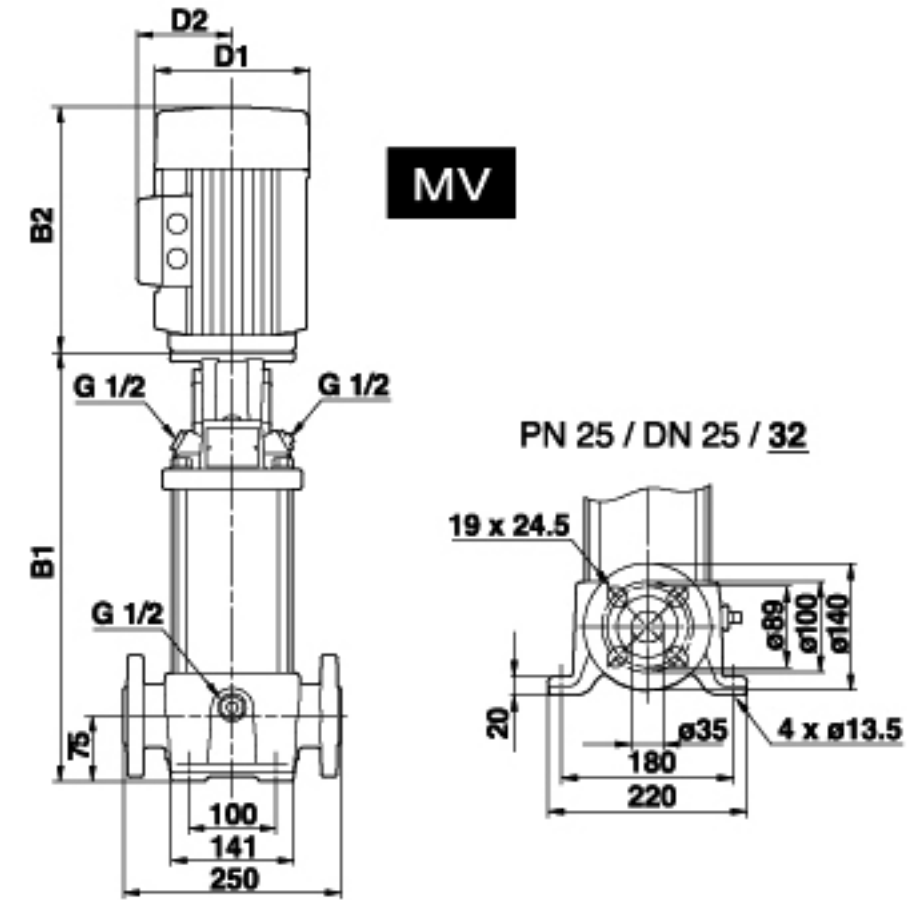
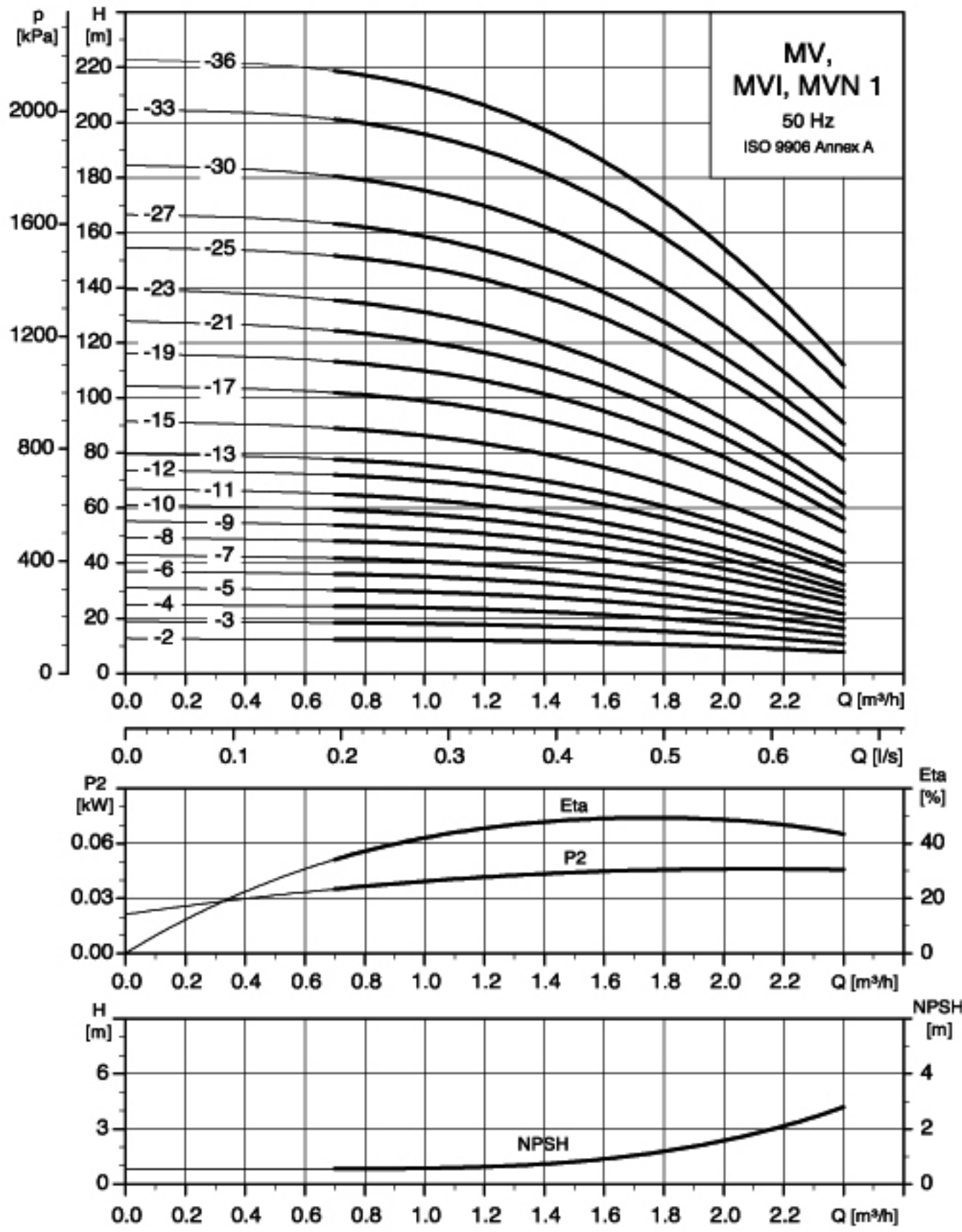
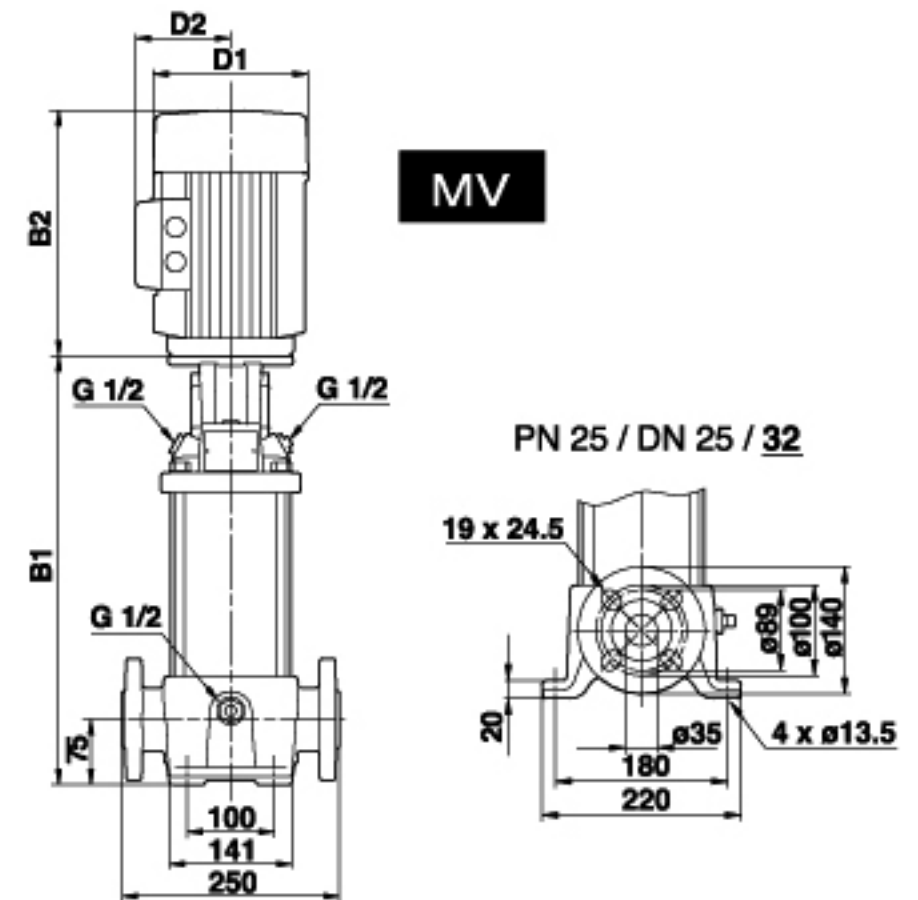
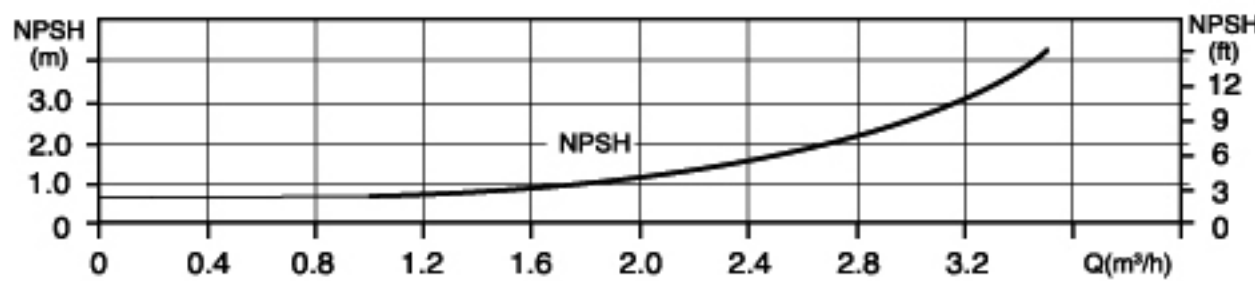
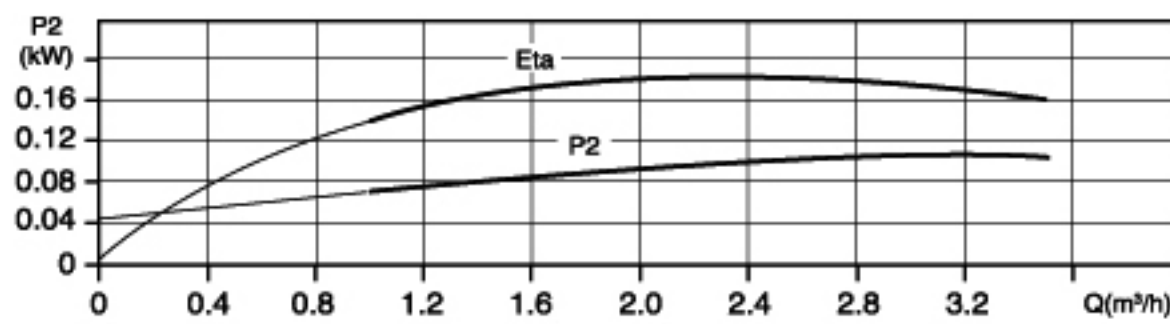
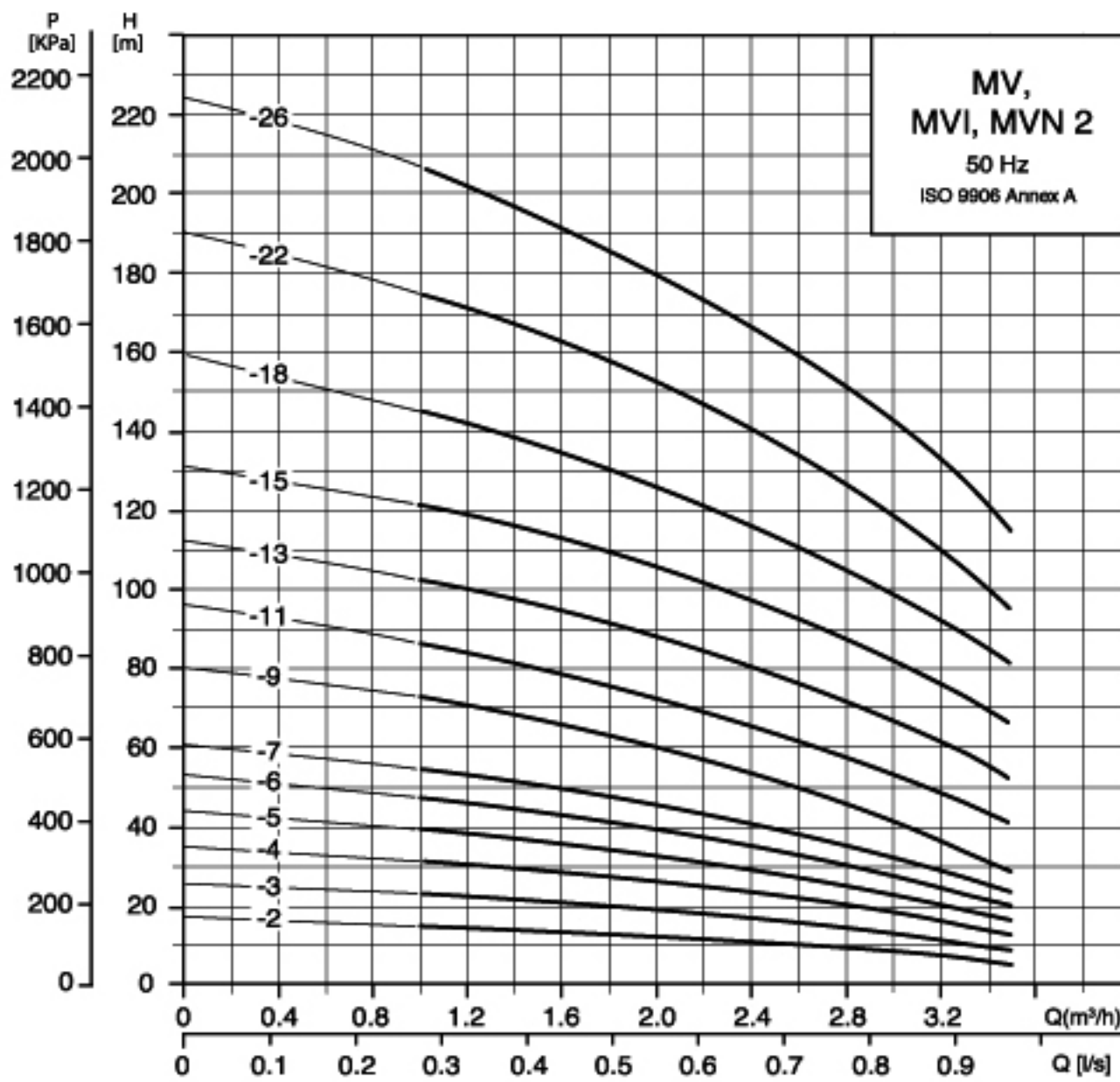
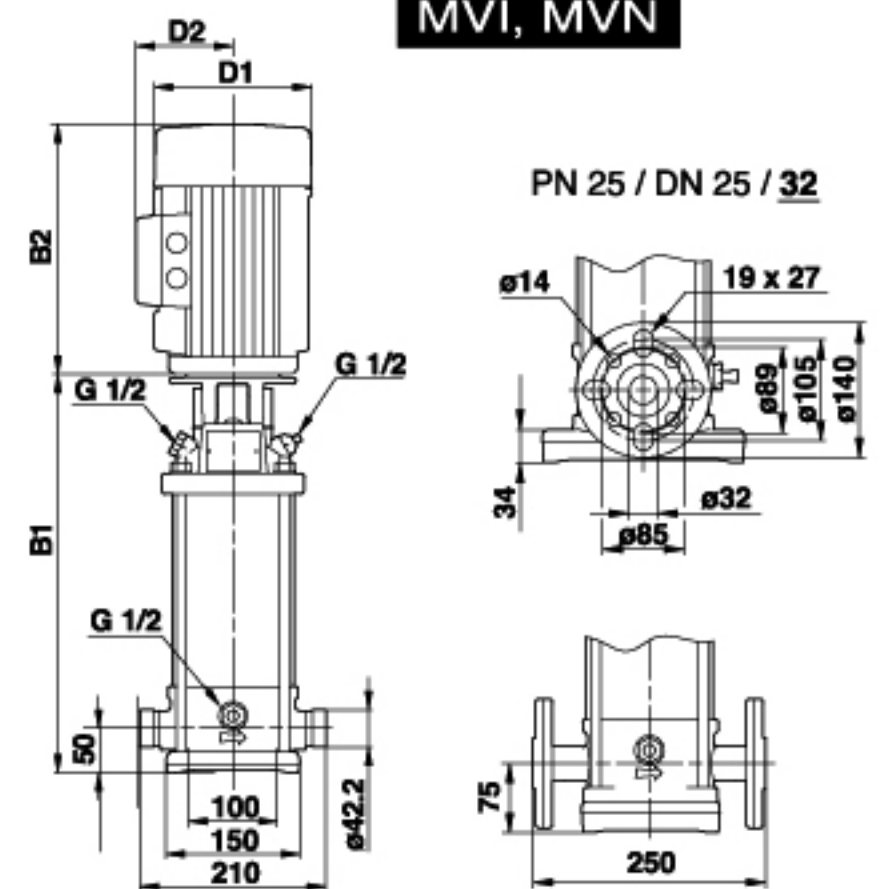

Fig. 27 Minimum flow rate

**Performance curves**

**Dimensions and weights**

Pump type	Motor P <sub>2</sub> [kW]	MV				Net weight [kg]	Pump type	Motor P <sub>2</sub> [kW]	MVI, MVN				Net weight [kg]
		Dimension [mm]							Dimension [mm]				
		B1	B1+B2	D1	D2			B1	B1+B2	D1	D2		
MV 1-2	0.37	279	470	141	109	23	MVI/MVN 1-2	0.37	282	473	141	109	20
MV 1-3	0.37	279	470	141	109	23	MVI/MVN 1-3	0.37	282	473	141	109	21
MV 1-4	0.37	297	488	141	109	23	MVI/MVN 1-4	0.37	300	491	141	109	21
MV 1-5	0.37	315	506	141	109	24	MVI/MVN 1-5	0.37	318	509	141	109	21
MV 1-6	0.37	333	524	141	109	24	MVI/MVN 1-6	0.37	336	527	141	109	22
MV 1-7	0.37	351	542	141	109	25	MVI/MVN 1-7	0.37	354	545	141	109	22
MV 1-8	0.55	369	560	141	109	26	MVI/MVN 1-8	0.55	372	563	141	109	23
MV 1-9	0.55	387	578	141	109	26	MVI/MVN 1-9	0.55	390	581	141	109	24
MV 1-10	0.55	405	596	141	109	26	MVI/MVN 1-10	0.55	408	599	141	109	24
MV 1-11	0.55	423	614	141	109	27	MVI/MVN 1-11	0.55	426	617	141	109	24
MV 1-12	0.75	447	678	141	109	29	MVI/MVN 1-12	0.75	450	681	141	109	27
MV 1-13	0.75	465	696	141	109	29	MVI/MVN 1-13	0.75	468	699	141	109	28
MV 1-15	0.75	501	732	141	109	30	MVI/MVN 1-15	0.75	504	735	141	109	28
MV 1-17	1.1	537	768	141	109	33	MVI/MVN 1-17	1.1	540	771	141	109	31
MV 1-19	1.1	573	804	141	109	34	MVI/MVN 1-19	1.1	576	807	141	109	32
MV 1-21	1.1	609	840	141	109	35	MVI/MVN 1-21	1.1	612	843	141	109	33
MV 1-23	1.1	645	876	141	109	36	MVI/MVN 1-23	1.1	648	879	141	109	34
MV 1-25	1.5	697	978	178	110	44	MVI/MVN 1-25	1.5	700	981	178	110	41
MV 1-27	1.5	733	1014	178	110	44	MVI/MVN 1-27	1.5	736	1017	178	110	42
MV 1-30	1.5	787	1068	178	110	46	MVI/MVN 1-30	1.5	790	1071	178	110	43
MV 1-33	2.2	841	1162	178	110	47	MVI/MVN 1-33	2.2	844	1165	178	110	45
MV 1-36	2.2	895	1216	178	110	49	MVI/MVN 1-36	2.2	898	1219	178	110	46

**Performance curves**

**MV**

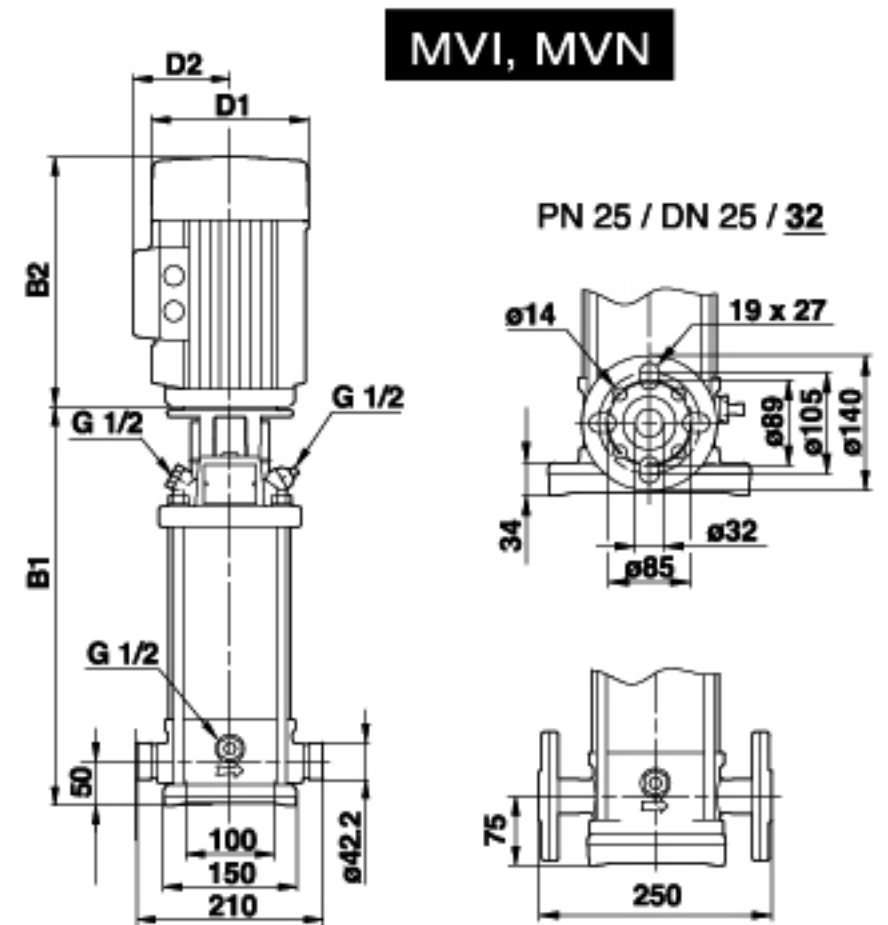
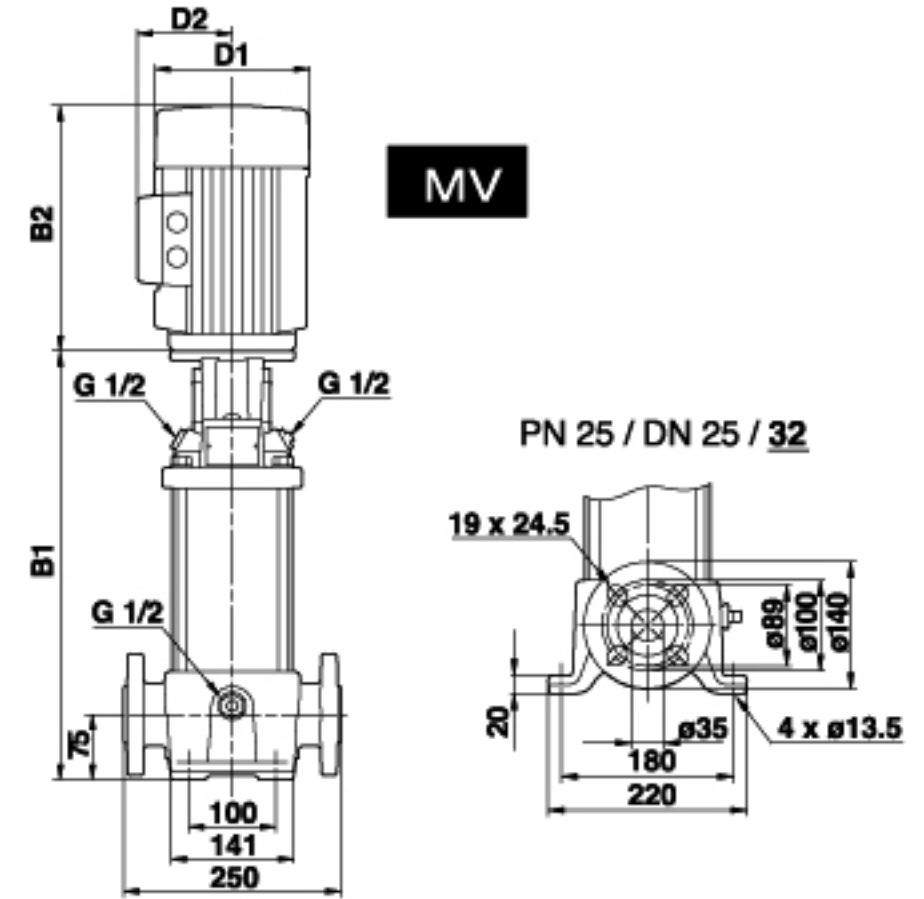
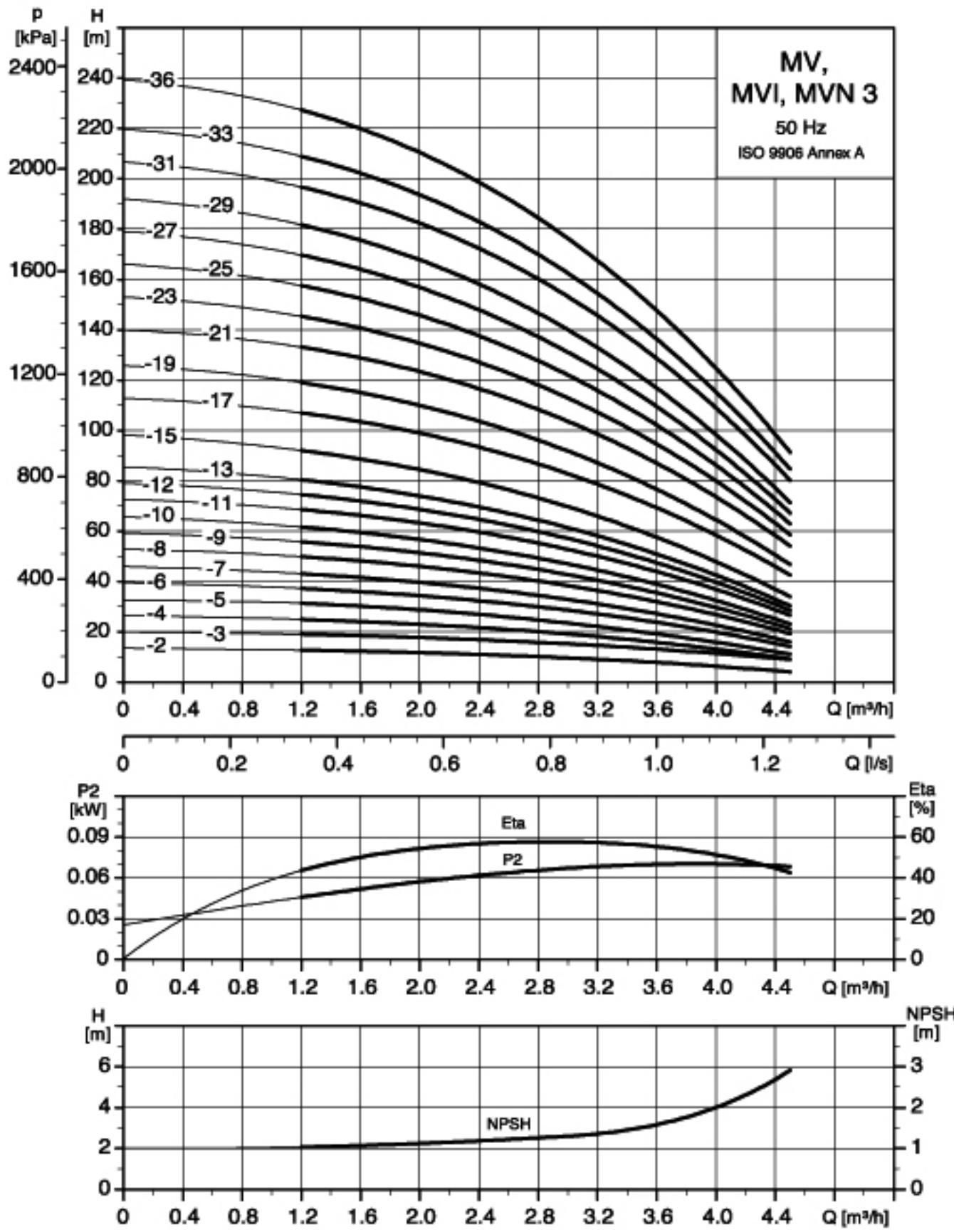
**MVI, MVN**
**Dimensions and weights**

Pump type	Motor P <sub>2</sub> [kW]	MV				Net weight [kg]
		Dimension [mm]				
		B1	B1+B2	D1	D2	
MV 2-2	0.37	259	464	133	102	21
MV 2-3	0.37	277	482	133	102	21
MV 2-4	0.55	295	500	133	102	23
MV 2-5	0.55	313	518	133	102	23
MV 2-6	0.75	331	536	133	102	25
MV 2-7	0.75	349	554	133	102	25
MV 2-9	1.1	391	632	154	111	27
MV 2-11	1.1	427	668	154	111	27
MV 2-13	1.5	463	704	154	111	29
MV 2-15	1.5	499	740	154	111	29
MV 2-18	2.2	565	830	177	116	35
MV 2-22	2.2	637	912	177	116	38
MV 2-26	3.0	709	984	177	116	45

Pump type	Motor P <sub>2</sub> [kW]	MVI, MVN				Net weight [kg]
		Dimension [mm]				
		B1	B1+B2	D1	D2	
MVI/MVN 2-2	0.37	259	464	133	102	21
MVI/MVN 2-3	0.37	277	482	133	102	21
MVI/MVN 2-4	0.55	295	500	133	102	23
MVI/MVN 2-5	0.55	313	518	133	102	23
MVI/MVN 2-6	0.75	331	536	133	102	25
MVI/MVN 2-7	0.75	349	554	133	102	25
MVI/MVN 2-9	1.1	391	632	154	111	27
MVI/MVN 2-11	1.1	427	668	154	111	27
MVI/MVN 2-13	1.5	463	704	154	111	29
MVI/MVN 2-15	1.5	499	740	154	111	29
MVI/MVN 2-18	2.2	565	830	177	116	35
MVI/MVN 2-22	2.2	637	912	177	116	38
MVI/MVN 2-26	3.0	709	984	177	116	45

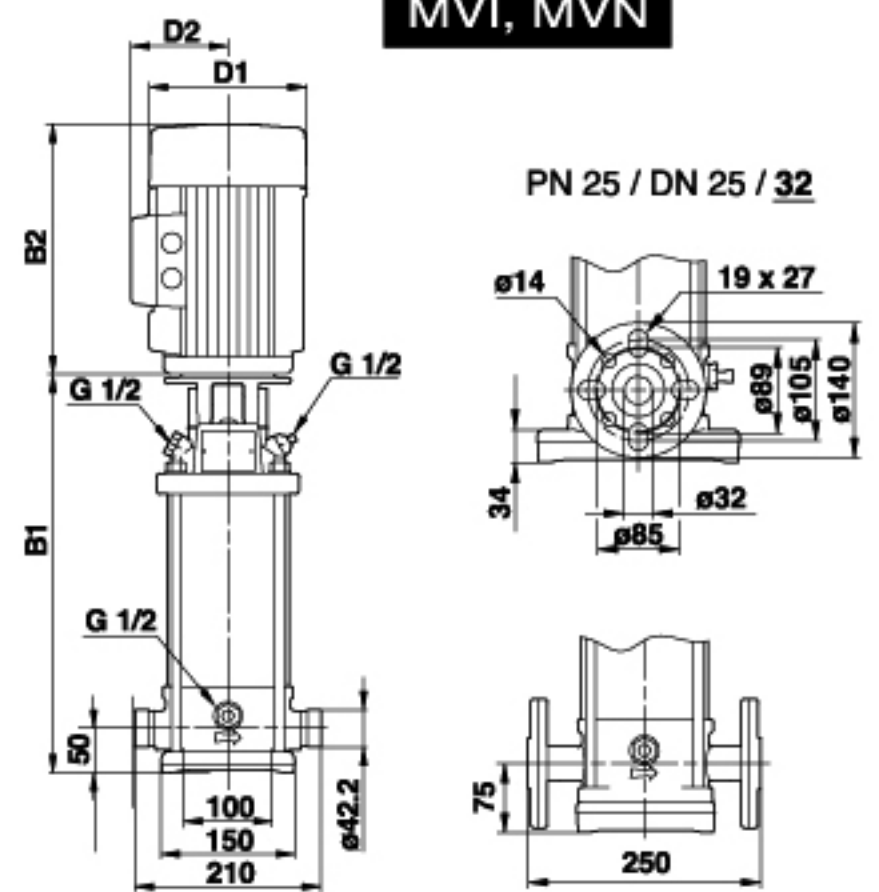
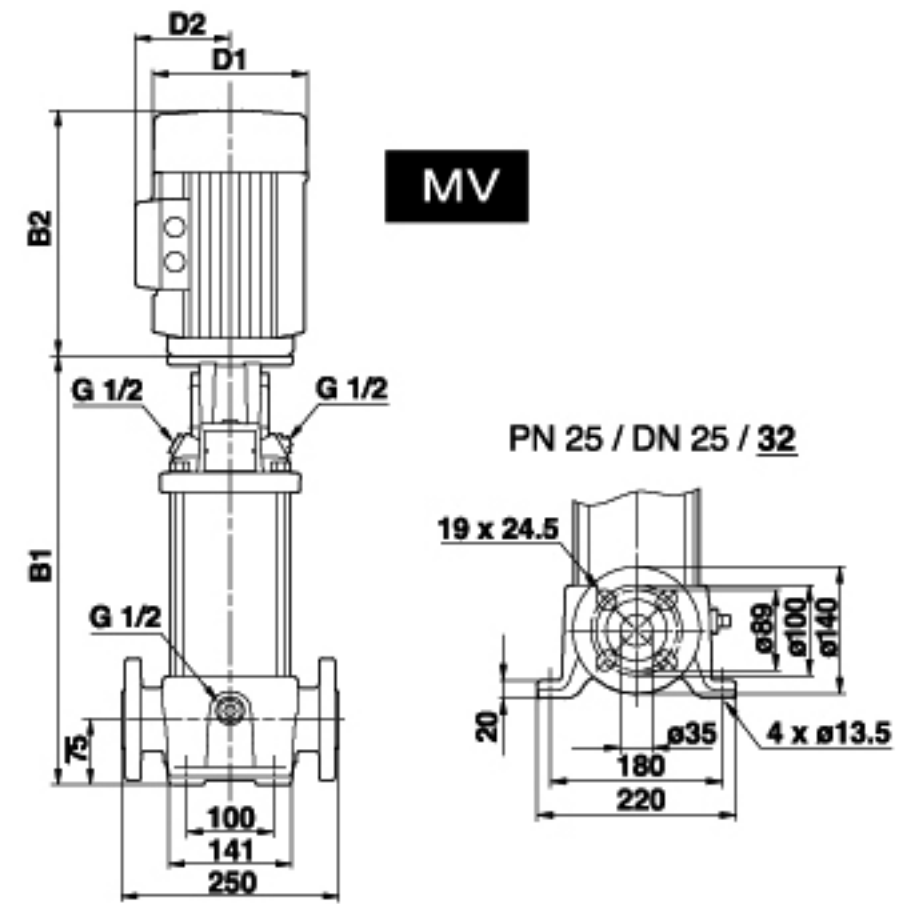
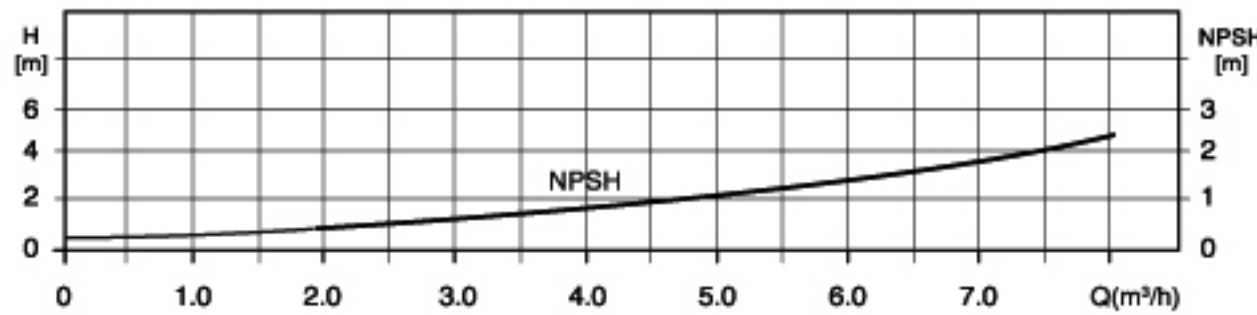
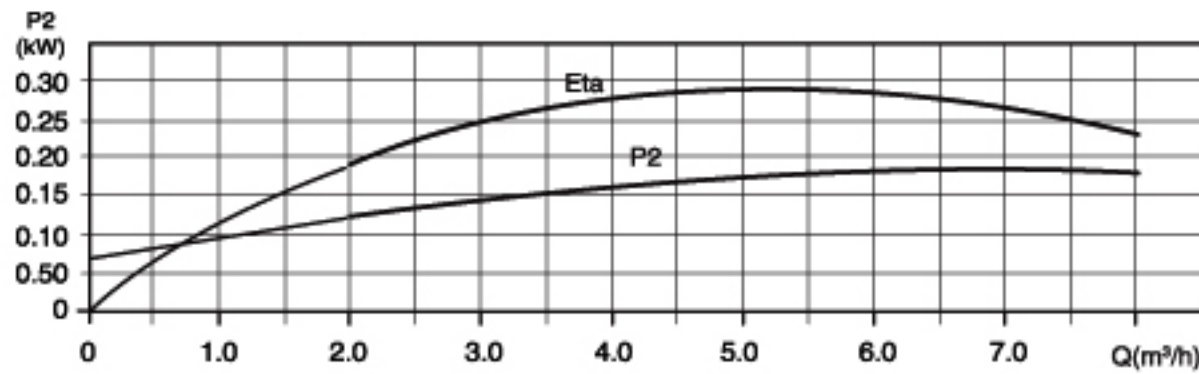
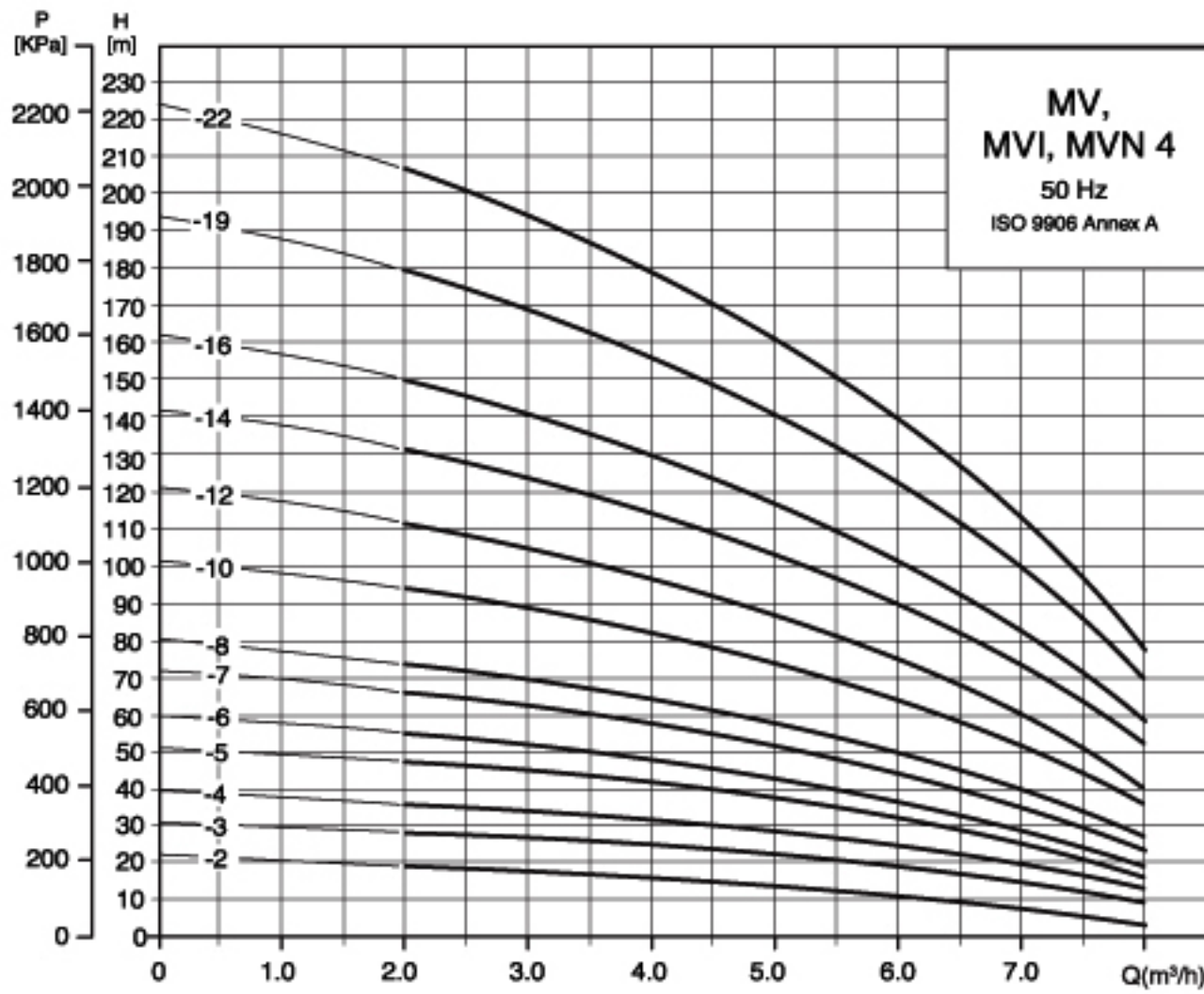
**Performance curves**

**Dimensions and weights**

Pump type	Motor P <sub>2</sub> [kW]	MV				Net weight [kg]	Pump type	Motor P <sub>2</sub> [kW]	MVI, MVN				Net weight [kg]
		Dimension [mm]							Dimension [mm]				
		B1	B1+B2	D1	D2			B1	B1+B2	D1	D2		
MV 3-2	0.37	279	470	141	109	23	MVI/MVN 3-2	0.37	282	473	141	109	19
MV 3-3	0.37	279	470	141	109	23	MVI/MVN 3-3	0.37	282	473	141	109	19
MV 3-4	0.37	297	488	141	109	23	MVI/MVN 3-4	0.37	300	491	141	109	19
MV 3-5	0.37	315	506	141	109	24	MVI/MVN 3-5	0.37	318	509	141	109	20
MV 3-6	0.55	333	524	141	109	25	MVI/MVN 3-6	0.55	336	527	141	109	21
MV 3-7	0.55	351	542	141	109	25	MVI/MVN 3-7	0.55	354	545	141	109	21
MV 3-8	0.75	375	606	141	109	27	MVI/MVN 3-8	0.75	378	609	141	109	24
MV 3-9	0.75	393	624	141	109	28	MVI/MVN 3-9	0.75	396	627	141	109	24
MV 3-10	0.75	411	642	141	109	28	MVI/MVN 3-10	0.75	414	645	141	109	25
MV 3-11	1.1	429	660	141	109	31	MVI/MVN 3-11	1.1	432	663	141	109	27
MV 3-12	1.1	447	678	141	109	31	MVI/MVN 3-12	1.1	450	681	141	109	28
MV 3-13	1.1	465	696	141	109	31	MVI/MVN 3-13	1.1	468	699	141	109	28
MV 3-15	1.1	501	732	141	109	32	MVI/MVN 3-15	1.1	504	735	141	109	29
MV 3-17	1.5	553	834	178	110	40	MVI/MVN 3-17	1.5	556	837	178	110	36
MV 3-19	1.5	589	870	178	110	41	MVI/MVN 3-19	1.5	592	873	178	110	37
MV 3-21	2.2	625	946	178	110	42	MVI/MVN 3-21	2.2	628	949	178	110	38
MV 3-23	2.2	661	982	178	110	43	MVI/MVN 3-23	2.2	664	985	178	110	39
MV 3-25	2.2	697	1018	178	110	44	MVI/MVN 3-25	2.2	700	1021	178	110	40
MV 3-27	2.2	733	1054	178	110	45	MVI/MVN 3-27	2.2	736	1057	178	110	41
MV 3-29	2.2	769	1090	178	110	46	MVI/MVN 3-29	2.2	772	1093	178	110	42
MV 3-31	3	809	1144	198	120	51	MVI/MVN 3-31	3	812	1147	198	120	47
MV 3-33	3	845	1180	198	120	51	MVI/MVN 3-33	3	848	1183	198	120	47
MV 3-36	3	899	1234	198	120	53	MVI/MVN 3-36	3	902	1237	198	120	49

**Performance curves**

**Dimensions and weights**

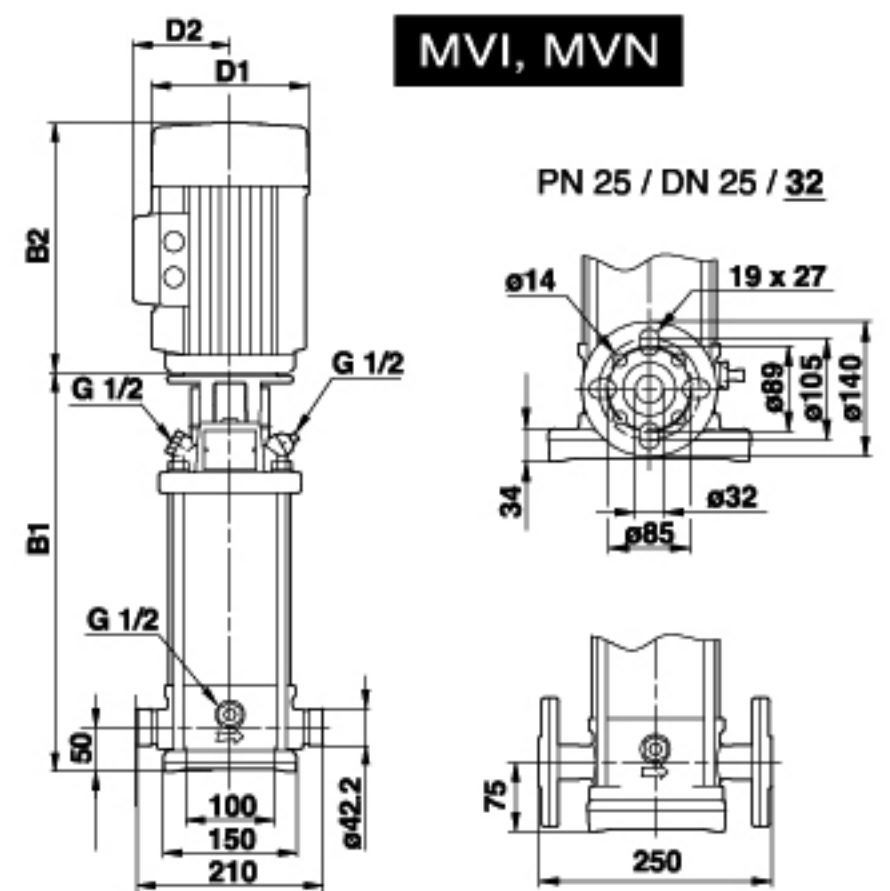
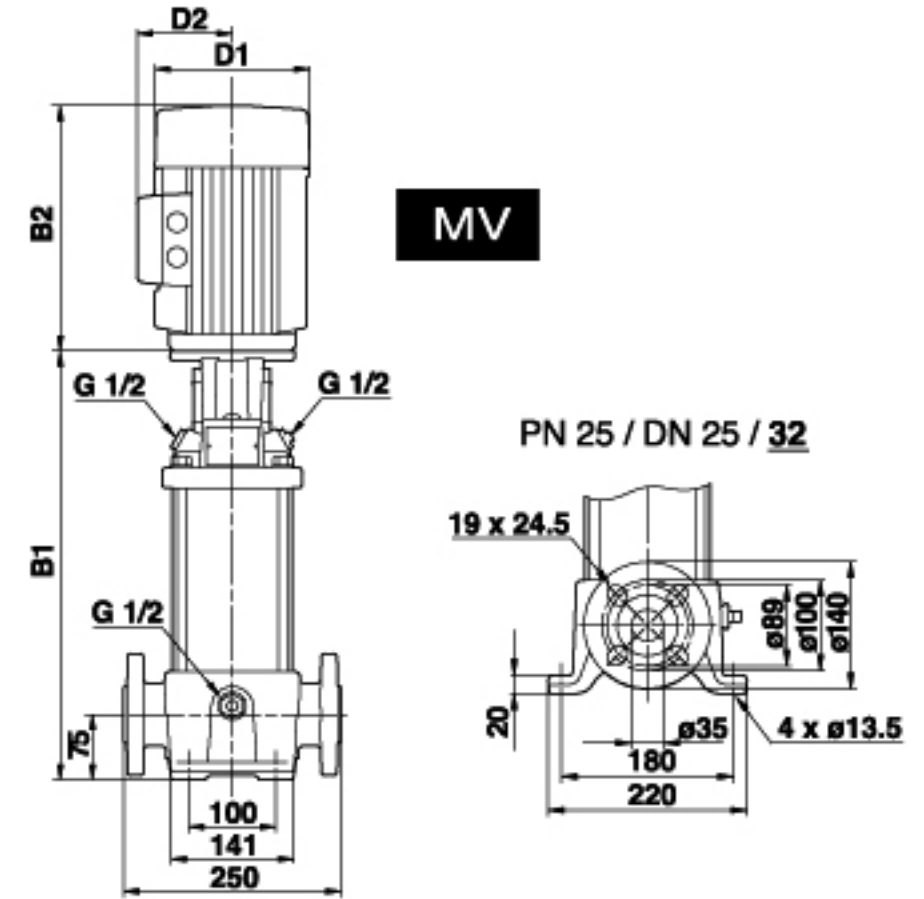
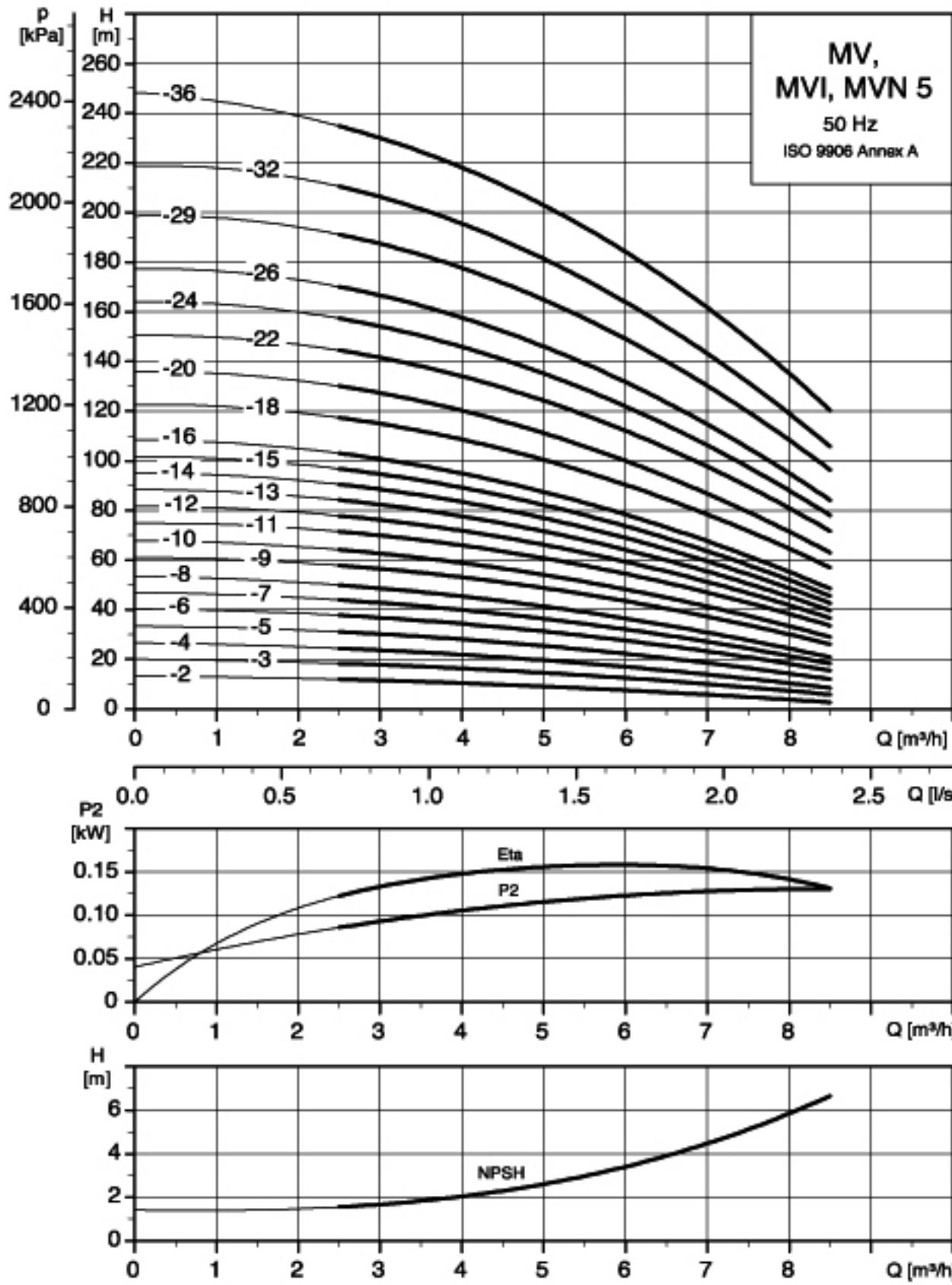
Pump type	Motor P <sub>2</sub> [kW]	MV				
		Dimension [mm]				Net weight [kg]
		B1	B1+B2	D1	D2	
MV 4-2	0.37	259	464	133	102	22
MV 4-3	0.55	277	482	133	102	22
MV 4-4	0.75	295	500	133	102	23
MV 4-5	1.1	319	560	154	111	23
MV 4-6	1.1	337	578	154	111	25
MV 4-7	1.5	355	596	154	111	30
MV 4-8	1.5	373	614	154	111	30
MV 4-10	2.2	417	692	177	116	32
MV 4-12	2.2	453	728	177	116	32
MV 4-14	3.0	489	764	177	116	35
MV 4-16	3.0	525	800	197	116	39
MV 4-19	4.0	599	904	197	148	45
MV 4-22	4.0	653	958	197	148	49

Pump type	Motor P <sub>2</sub> [kW]	MVI, MVN				
		Dimension [mm]				Net weight [kg]
		B1	B1+B2	D1	D2	
MVI/MVN 4-2	0.37	259	464	133	102	22
MVI/MVN 4-3	0.55	277	482	133	102	22
MVI/MVN 4-4	0.75	295	500	133	102	23
MVI/MVN 4-5	1.1	319	560	154	111	23
MVI/MVN 4-6	1.1	337	578	154	111	25
MVI/MVN 4-7	1.5	355	596	154	111	30
MVI/MVN 4-8	1.5	373	614	154	111	30
MVI/MVN 4-10	2.2	417	692	177	116	32
MVI/MVN 4-12	2.2	453	728	177	116	32
MVI/MVN 4-14	3.0	489	764	177	116	35
MVI/MVN 4-16	3.0	525	800	197	116	39
MVI/MVN 4-19	4.0	599	904	197	148	45
MVI/MVN 4-22	4.0	653	958	197	148	49

**Performance curves**

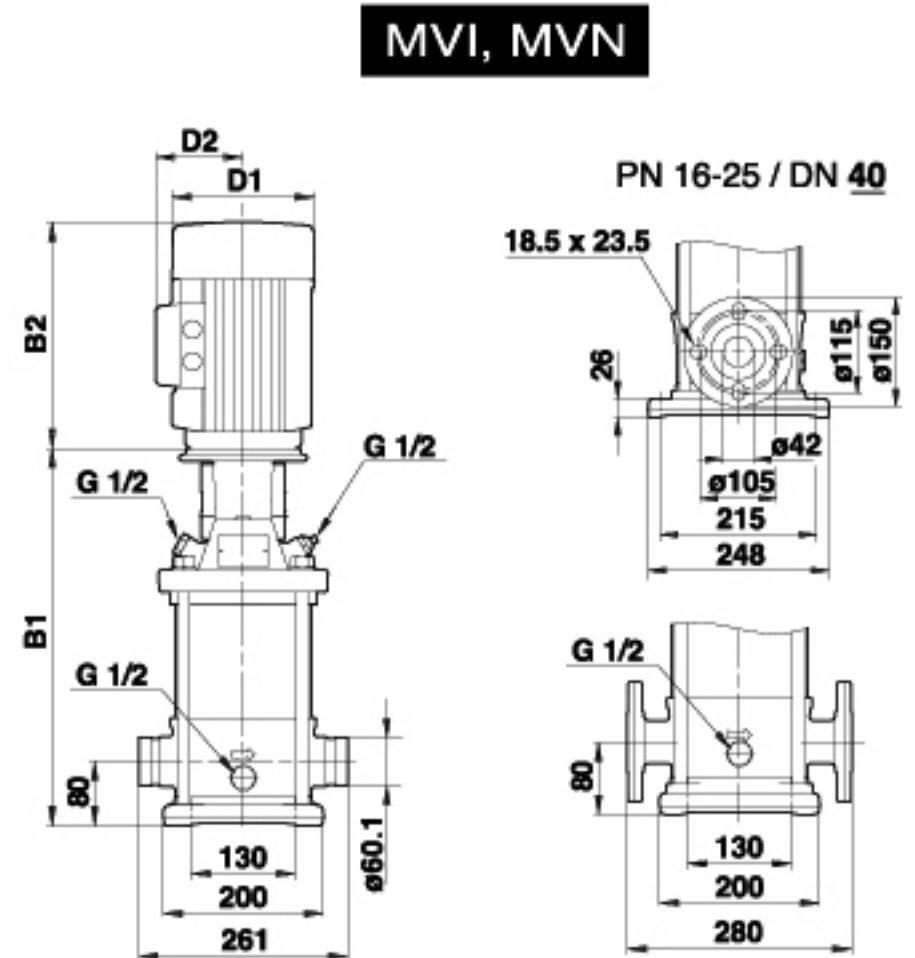
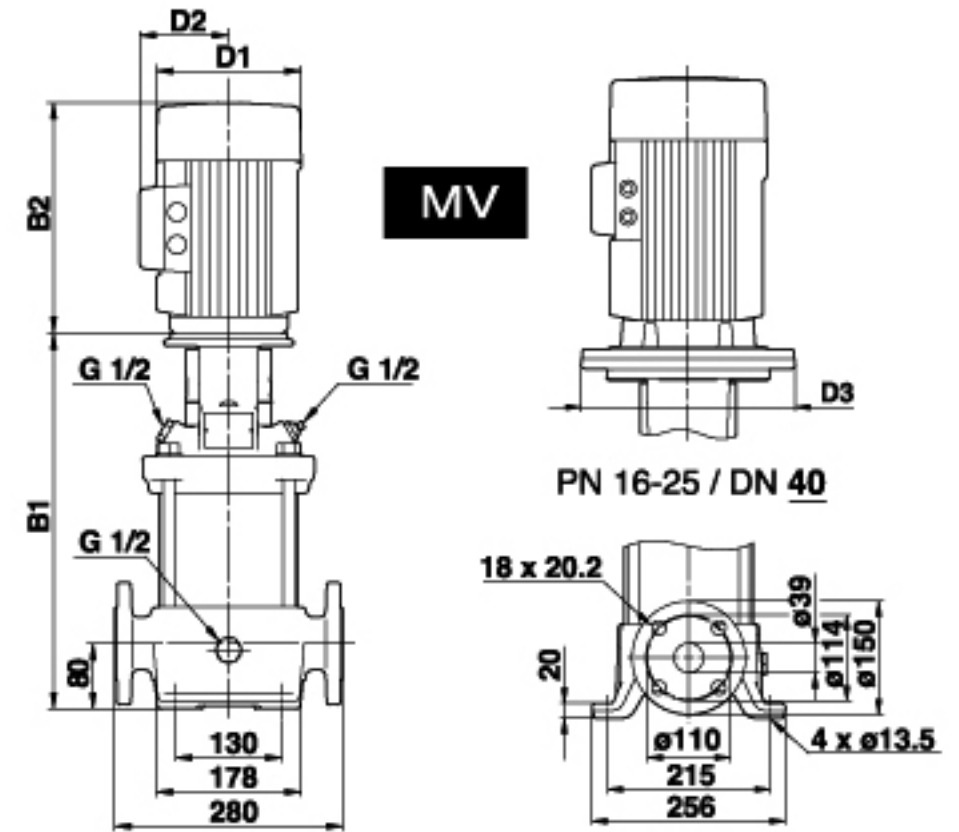
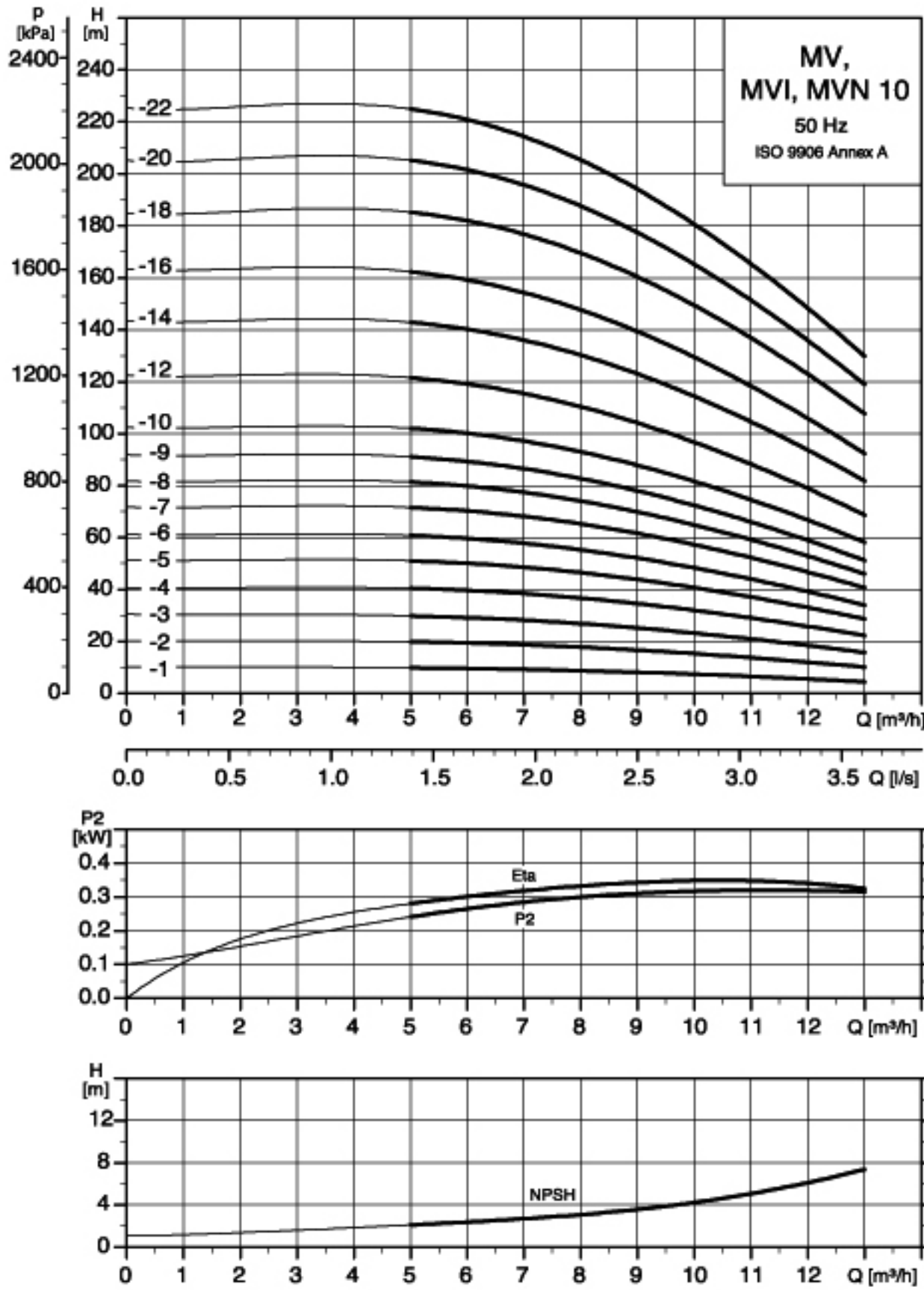
**Dimensions and weights**

Pump type	Motor P <sub>2</sub> [kW]	MV					Net weight [kg]	Pump type	Motor P <sub>2</sub> [kW]	MVI, MVN					Net weight [kg]
		Dimension [mm]								Dimension [mm]					
		B1	B1+B2	D1	D2	D3			B1	B1+B2	D1	D2	D3		
MV 5-2	0.37	279	470	141	109	-	23	MVI/MVN 5-2	0.37	282	473	141	109	-	21
MV 5-3	0.55	306	497	141	109	-	24	MVI/MVN 5-3	0.55	309	500	141	109	-	22
MV 5-4	0.55	333	524	141	109	-	25	MVI/MVN 5-4	0.55	336	527	141	109	-	22
MV 5-5	0.75	366	597	141	109	-	27	MVI/MVN 5-5	0.75	369	600	141	109	-	25
MV 5-6	1.1	393	624	141	109	-	30	MVI/MVN 5-6	1.1	396	627	141	109	-	28
MV 5-7	1.1	420	651	141	109	-	30	MVI/MVN 5-7	1.1	423	654	141	109	-	28
MV 5-8	1.1	447	678	141	109	-	31	MVI/MVN 5-8	1.1	450	681	141	109	-	29
MV 5-9	1.5	490	771	178	110	-	38	MVI/MVN 5-9	1.5	493	774	178	110	-	36
MV 5-10	1.5	517	798	178	110	-	39	MVI/MVN 5-10	1.5	520	801	178	110	-	37
MV 5-11	2.2	544	865	178	110	-	40	MVI/MVN 5-11	2.2	547	868	178	110	-	38
MV 5-12	2.2	571	892	178	110	-	41	MVI/MVN 5-12	2.2	574	895	178	110	-	38
MV 5-13	2.2	598	919	178	110	-	41	MVI/MVN 5-13	2.2	601	922	178	110	-	39
MV 5-14	2.2	625	946	178	110	-	42	MVI/MVN 5-14	2.2	628	949	178	110	-	40
MV 5-15	2.2	652	973	178	110	-	43	MVI/MVN 5-15	2.2	655	976	178	110	-	40
MV 5-16	2.2	679	1000	178	110	-	43	MVI/MVN 5-16	2.2	682	1003	178	110	-	41
MV 5-18	3.0	737	1072	198	120	-	48	MVI/MVN 5-18	3.0	740	1075	198	120	-	46
MV 5-20	3.0	791	1126	198	120	-	50	MVI/MVN 5-20	3.0	794	1129	198	120	-	47
MV 5-22	4.0	845	1217	220	134	-	62	MVI/MVN 5-22	4.0	848	1220	220	134	-	59
MV 5-24	4.0	899	1271	220	134	-	63	MVI/MVN 5-24	4.0	902	1274	220	134	-	61
MV 5-26	4.0	953	1325	220	134	-	64	MVI/MVN 5-26	4.0	956	1328	220	134	-	62
MV 5-29	4.0	1034	1406	220	134	-	66	MVI/MVN 5-29	4.0	1037	1409	220	134	-	64
MV 5-32	5.5	1145	1536	220	134	300	82	MVI/MVN 5-32	5.5	1148	1539	220	134	300	79
MV 5-36	5.5	1253	1644	220	134	300	84	MVI/MVN 5-36	5.5	1256	1647	220	134	300	81

**Performance curves**

**Dimensions and weights**

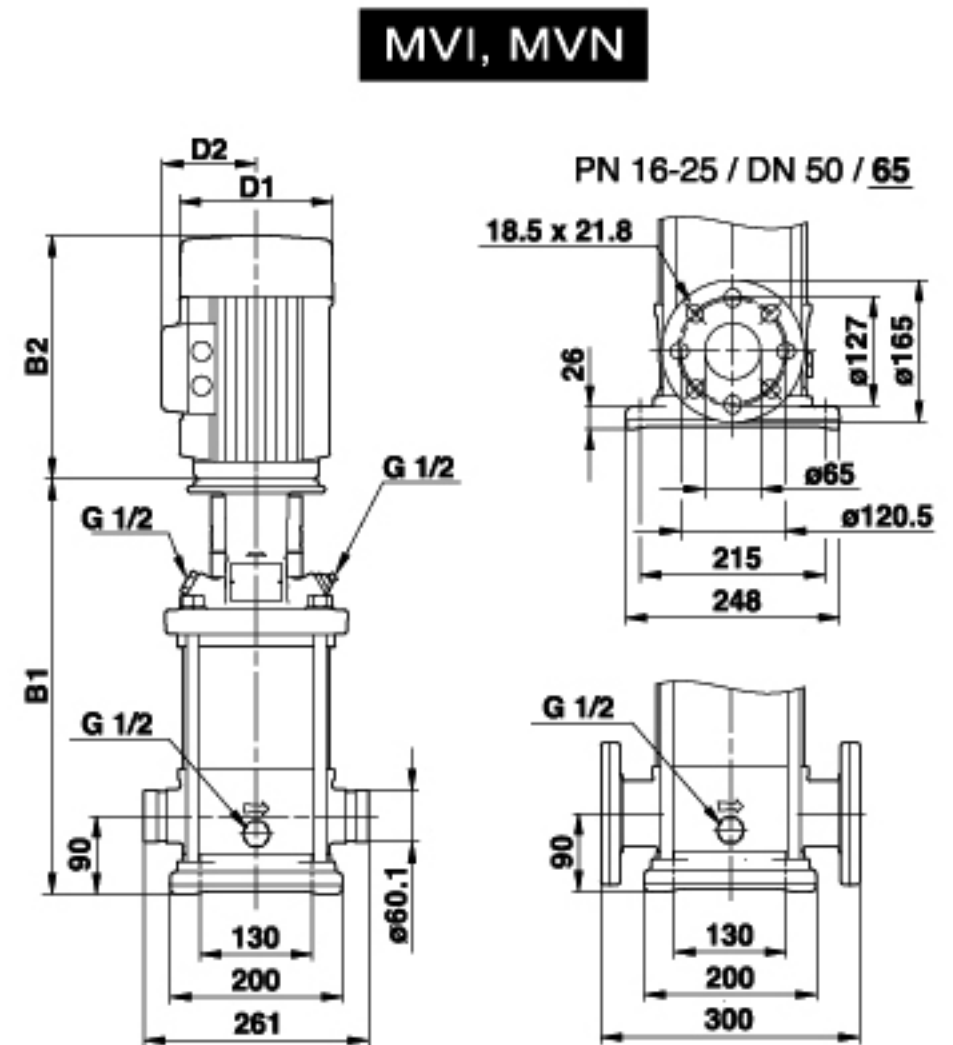
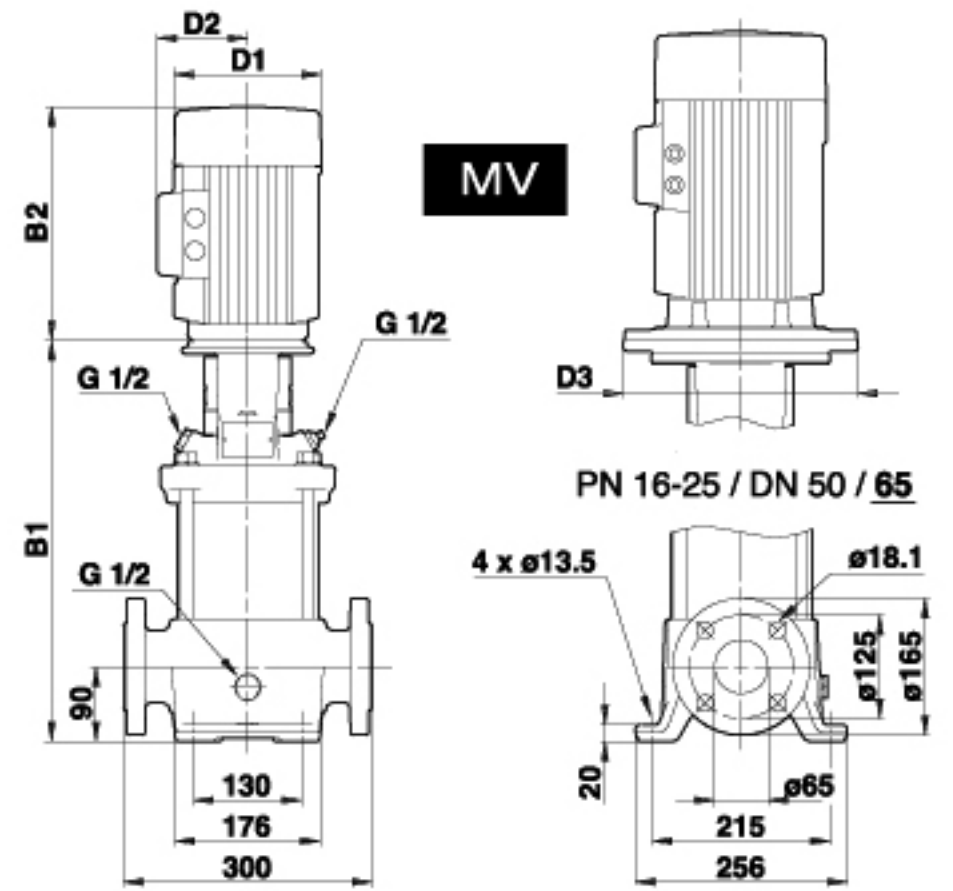
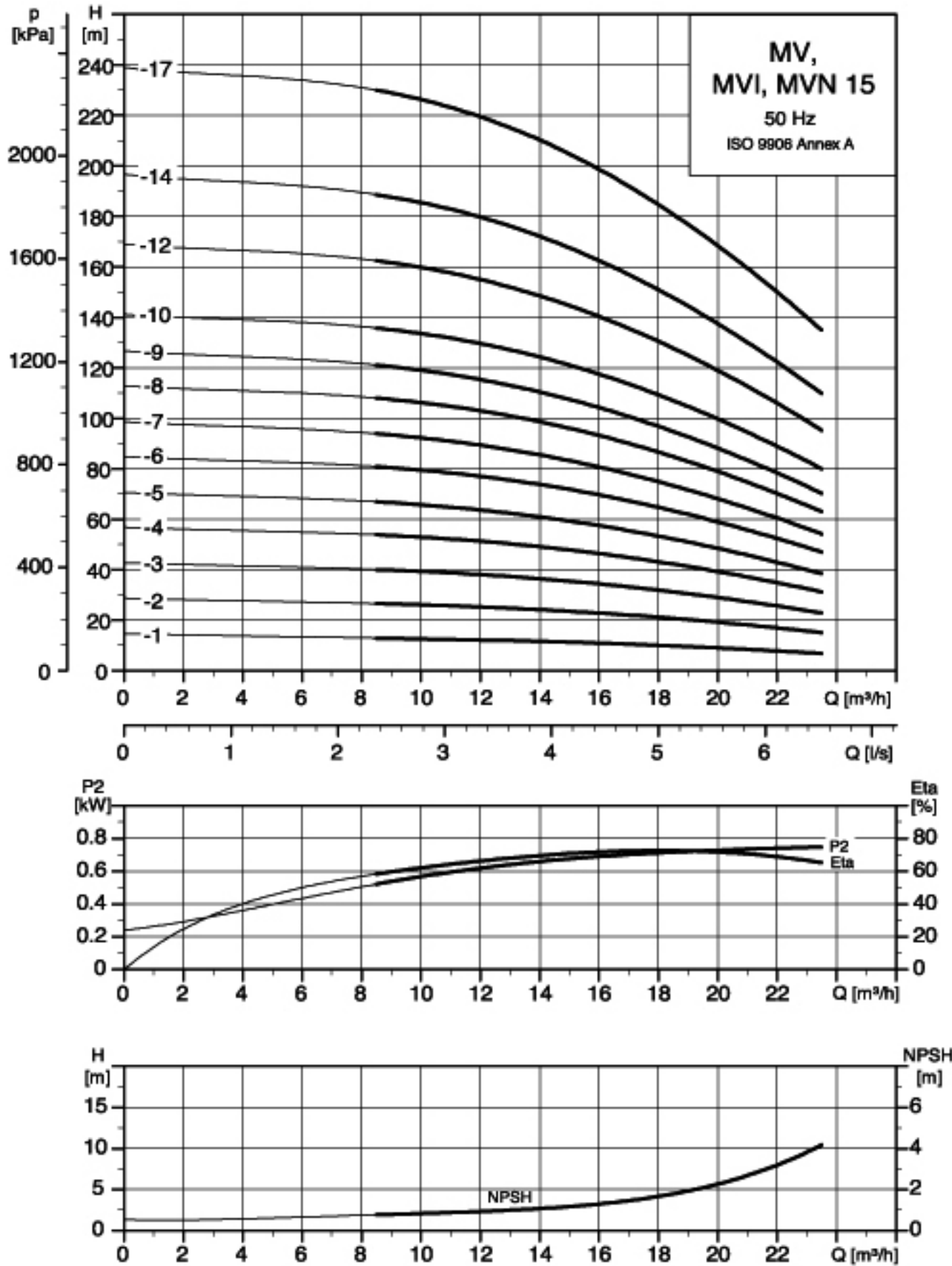
Pump type	Motor P <sub>2</sub> [kW]	MV					Net weight [kg]
		Dimension [mm]					
		B1	B1+B2	D1	D2	D3	
MV 10-1	0.37	343	534	141	109	-	34
MV 10-2	0.75	347	578	141	109	-	36
MV 10-3	1.1	377	608	141	109	-	39
MV 10-4	1.5	423	704	178	110	-	47
MV 10-5	2.2	453	734	178	110	-	49
MV 10-6	2.2	483	764	178	110	-	50
MV 10-7	3.0	518	853	198	120	-	55
MV 10-8	3.0	548	883	198	120	-	56
MV 10-9	3.0	578	913	198	120	-	57
MV 10-10	4.0	608	980	220	134	-	69
MV 10-12	4.0	668	1040	220	134	-	71
MV 10-14	5.5	760	1151	220	134	300	94
MV 10-16	5.5	820	1211	220	134	300	96
MV 10-18	7.5	880	1271	220	134	300	101
MV 10-20	7.5	940	1331	220	134	300	103
MV 10-22	7.5	1000	1391	220	134	300	105

Pump type	Motor P <sub>2</sub> [kW]	MVI, MVN					Net weight [kg]
		Dimension [mm]					
		B1	B1+B2	D1	D2	D3	
MVI/MVN 10-1	0.37	353	544	141	109	-	32
MVI/MVN 10-2	0.75	357	588	141	109	-	34
MVI/MVN 10-3	1.1	387	618	141	109	-	38
MVI/MVN 10-4	1.5	433	714	178	110	-	46
MVI/MVN 10-5	2.2	463	784	178	110	-	47
MVI/MVN 10-6	2.2	493	814	178	110	-	48
MVI/MVN 10-7	3.0	528	863	198	120	-	54
MVI/MVN 10-8	3.0	558	893	198	120	-	55
MVI/MVN 10-9	3.0	588	923	198	120	-	56
MVI/MVN 10-10	4.0	618	990	220	134	-	68
MVI/MVN 10-12	4.0	678	1050	220	134	-	70
MVI/MVN 10-14	5.5	770	1161	220	134	300	92
MVI/MVN 10-16	5.5	830	1221	220	134	300	94
MVI/MVN 10-18	7.5	890	1281	220	134	300	99
MVI/MVN 10-20	7.5	950	1341	220	134	300	101
MVI/MVN 10-22	7.5	1010	1401	220	134	300	104

**Performance curves**

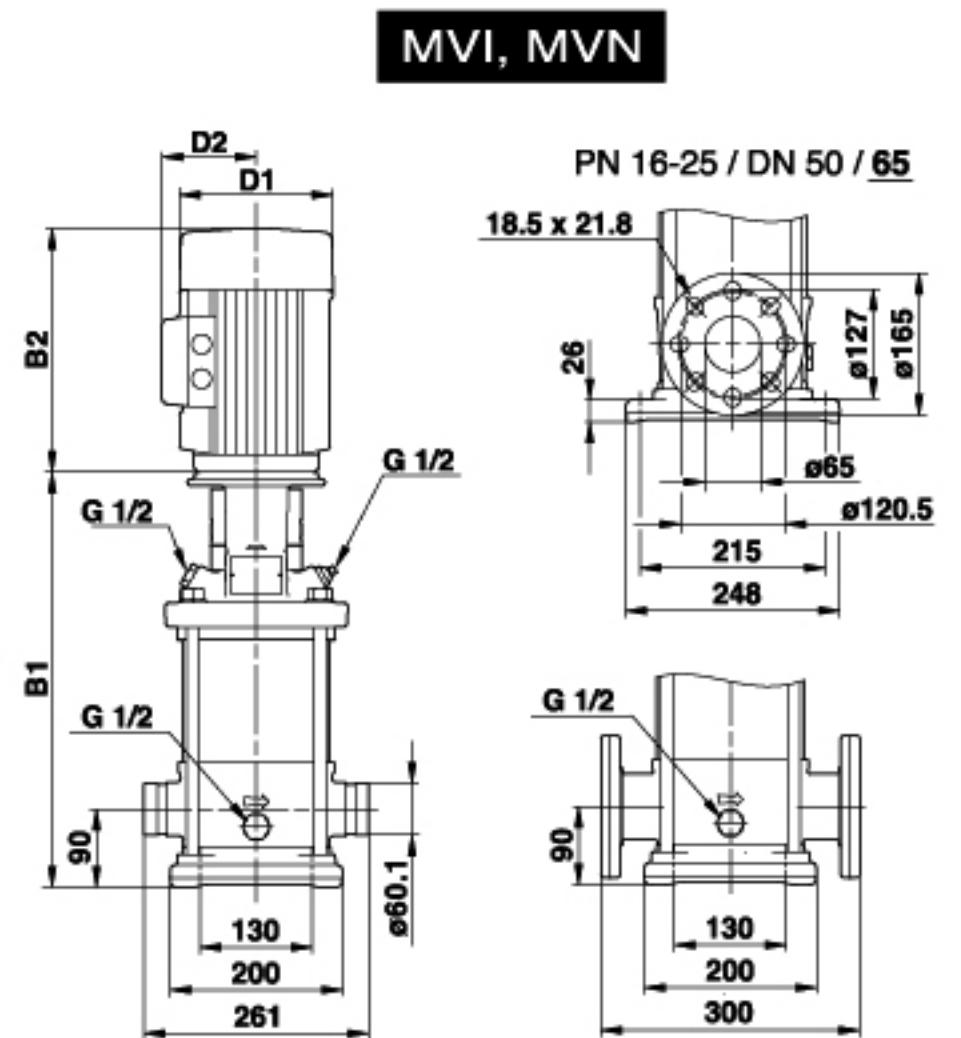
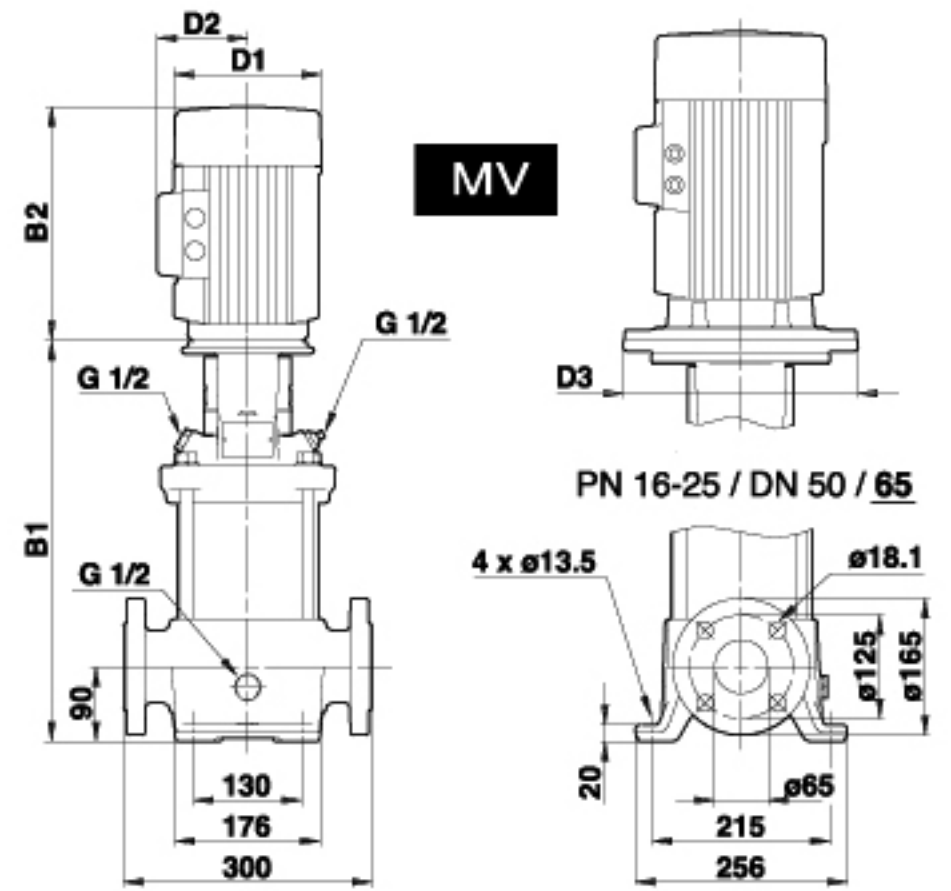
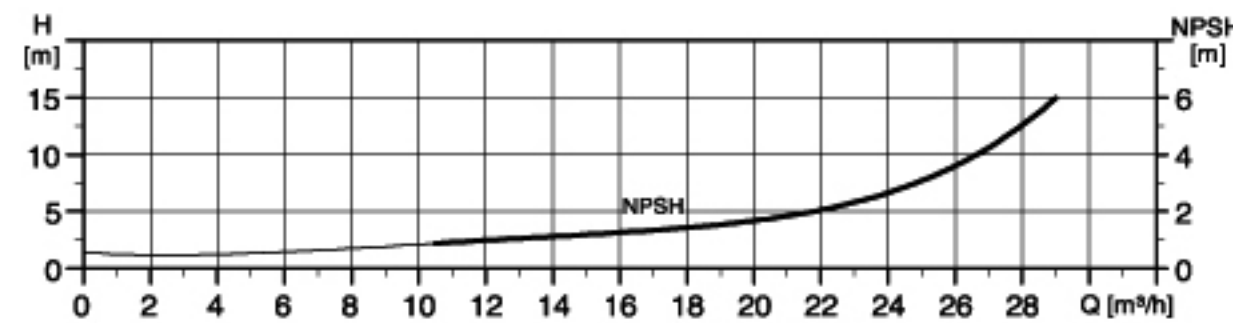
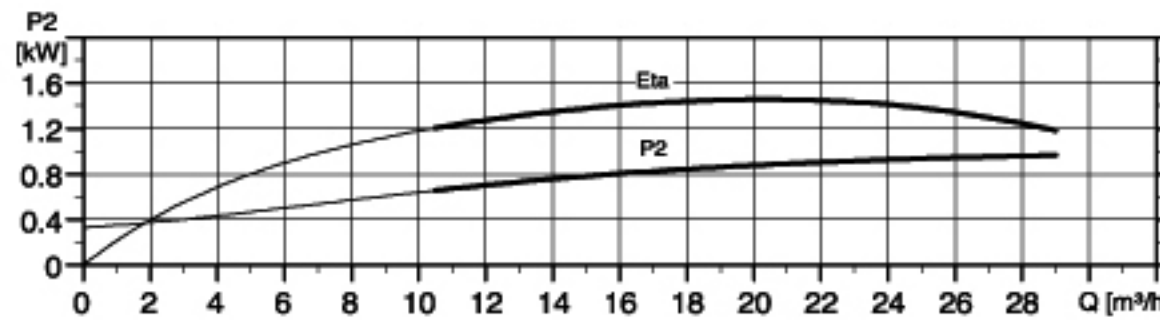
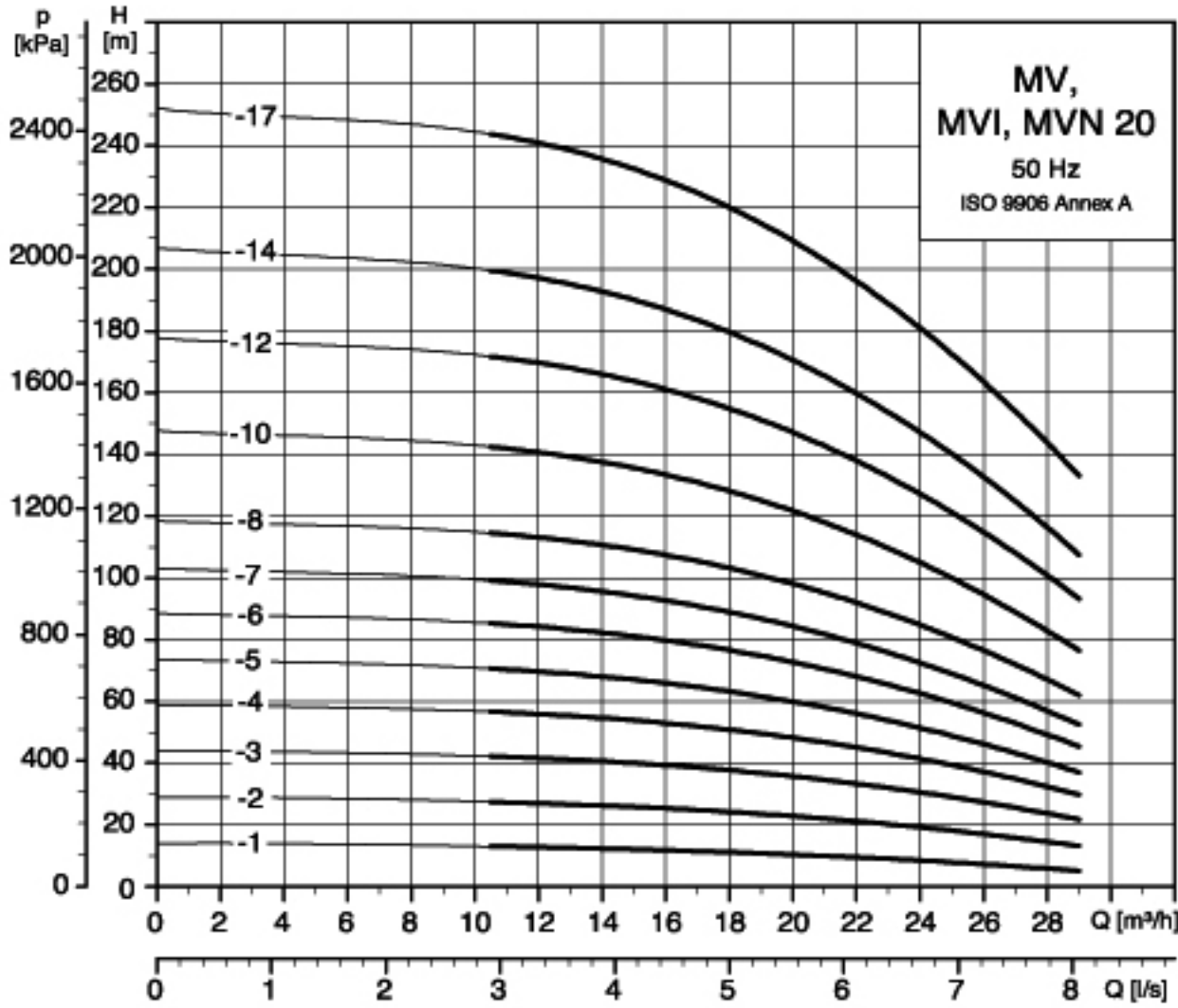
**Dimensions and weights**

Pump type	Motor P <sub>2</sub> [kW]	MV					Net weight [kg]	Pump type	Motor P <sub>2</sub> [kW]	MVI, MVN					Net weight [kg]
		B1	B1+B2	D1	D2	D3				B1	B1+B2	D1	D2	D3	
MV 15-1	1.1	400	631	141	109	-	42	MVI/MVN 15-1	1.1	400	631	141	109	-	42
MV 15-2	2.2	415	736	178	110	-	50	MVI/MVN 15-2	2.2	415	736	178	110	-	50
MV 15-3	3.0	465	800	198	120	-	55	MVI/MVN 15-3	3.0	465	800	198	120	-	55
MV 15-4	4.0	510	882	220	134	-	68	MVI/MVN 15-4	4.0	510	882	220	134	-	68
MV 15-5	4.0	555	927	220	134	-	69	MVI/MVN 15-5	4.0	555	927	220	134	-	69
MV 15-6	5.5	632	1023	220	134	300	91	MVI/MVN 15-6	5.5	632	1023	220	134	300	91
MV 15-7	5.5	677	1068	220	134	300	93	MVI/MVN 15-7	5.5	677	1068	220	134	300	93
MV 15-8	7.5	722	1113	220	134	300	97	MVI/MVN 15-8	7.5	722	1113	220	134	300	97
MV 15-9	7.5	767	1158	220	134	300	98	MVI/MVN 15-9	7.5	767	1158	220	134	300	98
MV 15-10	11.0	889	1388	260	172	350	130	MVI/MVN 15-10	11.0	889	1388	260	172	350	130
MV 15-12	11.0	979	1478	260	172	350	134	MVI/MVN 15-12	11.0	979	1478	260	172	350	134
MV 15-14	11.0	1069	1568	260	172	350	138	MVI/MVN 15-14	11.0	1069	1568	260	172	350	138
MV 15-17	15.0	1204	1682	320	197	350	157	MVI/MVN 15-17	15.0	1204	1682	320	197	350	157

**Performance curves**

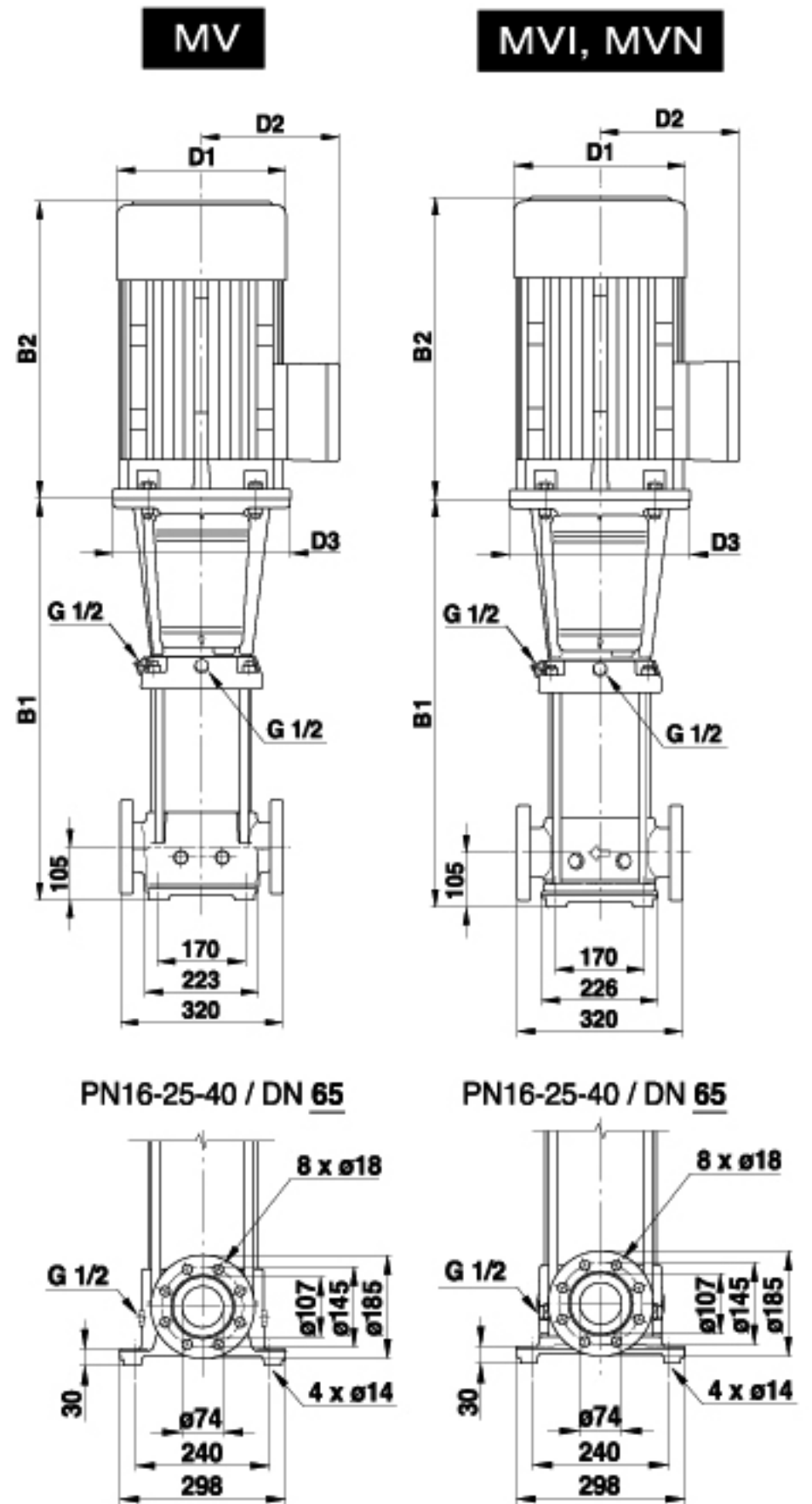
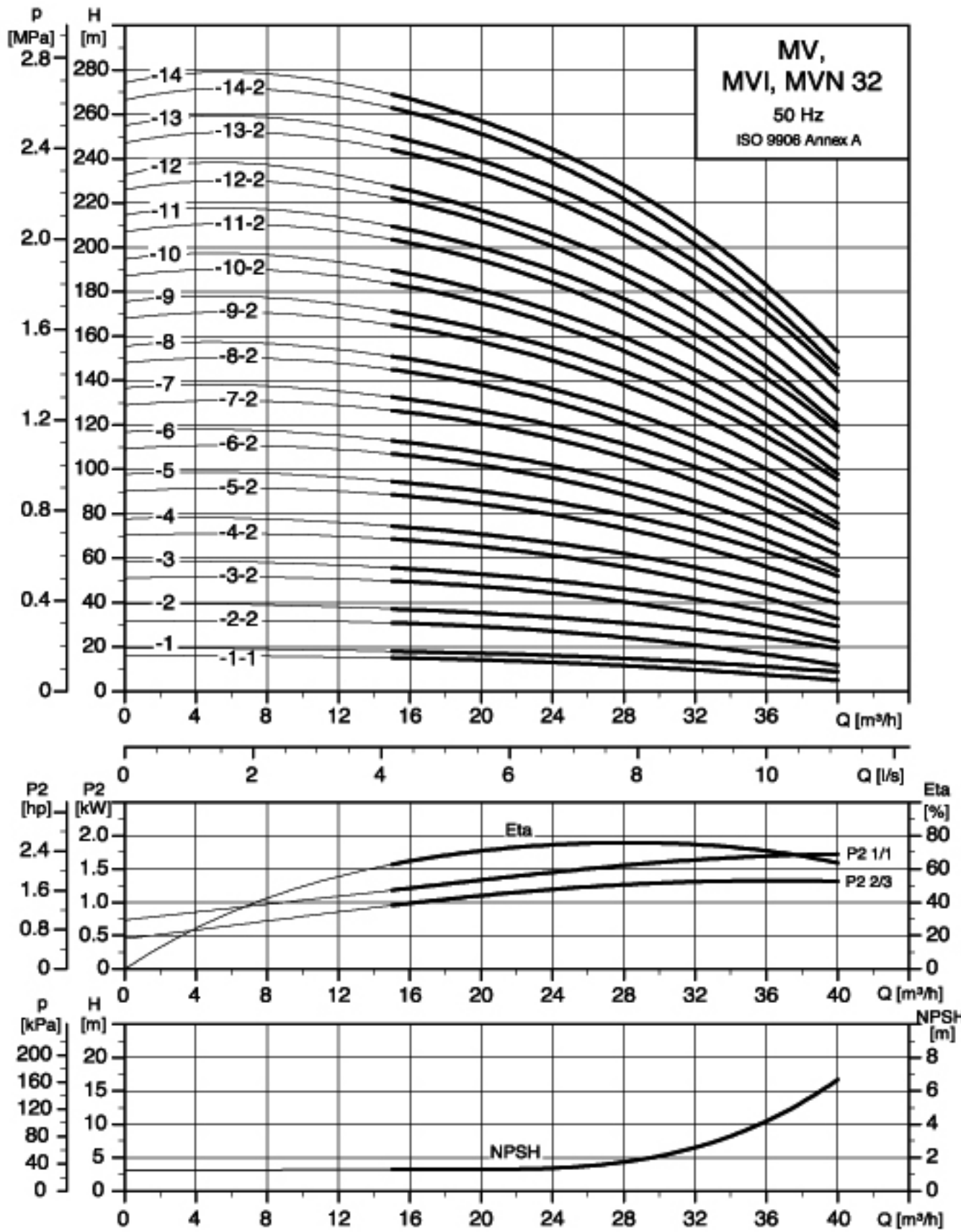
**Dimensions and weights**

Pump type	Motor P <sub>2</sub> [kW]	MV					Net weight [kg]	Pump type	Motor P <sub>2</sub> [kW]	MVI, MVN					Net weight [kg]
		B1	B1+B2	D1	D2	D3				B1	B1+B2	D1	D2	D3	
MV 20-1	1.1	400	631	141	109	-	42	MVI/MVN 20-1	1.1	397	628	141	109	-	39
MV 20-2	2.2	415	736	178	110	-	50	MVI/MVN 20-2	2.2	413	734	178	110	-	47
MV 20-3	4.0	465	837	220	134	-	66	MVI/MVN 20-3	4.0	463	835	220	134	-	63
MV 20-4	5.5	542	933	220	134	300	88	MVI/MVN 20-4	5.5	540	931	220	134	300	85
MV 20-5	5.5	587	978	220	134	300	90	MVI/MVN 20-5	5.5	585	976	220	134	300	87
MV 20-6	7.5	632	1023	220	134	300	93	MVI/MVN 20-6	7.5	630	1021	220	134	300	90
MV 20-7	7.5	677	1068	220	134	300	95	MVI/MVN 20-7	7.5	675	1066	220	134	300	92
MV 20-8	11.0	799	1298	260	172	350	127	MVI/MVN 20-8	11.0	797	1296	260	172	350	123
MV 20-10	11.0	889	1388	260	172	350	130	MVI/MVN 20-10	11.0	887	1386	260	172	350	127
MV 20-12	15.0	979	1457	320	197	350	148	MVI/MVN 20-12	15.0	977	1455	320	197	350	145
MV 20-14	15.0	1069	1547	320	197	350	152	MVI/MVN 20-14	15.0	1067	1545	320	197	350	148
MV 20-17	18.5	1204	1722	320	197	350	187	MVI/MVN 20-17	18.5	1202	1720	320	197	350	183

**Performance curves**

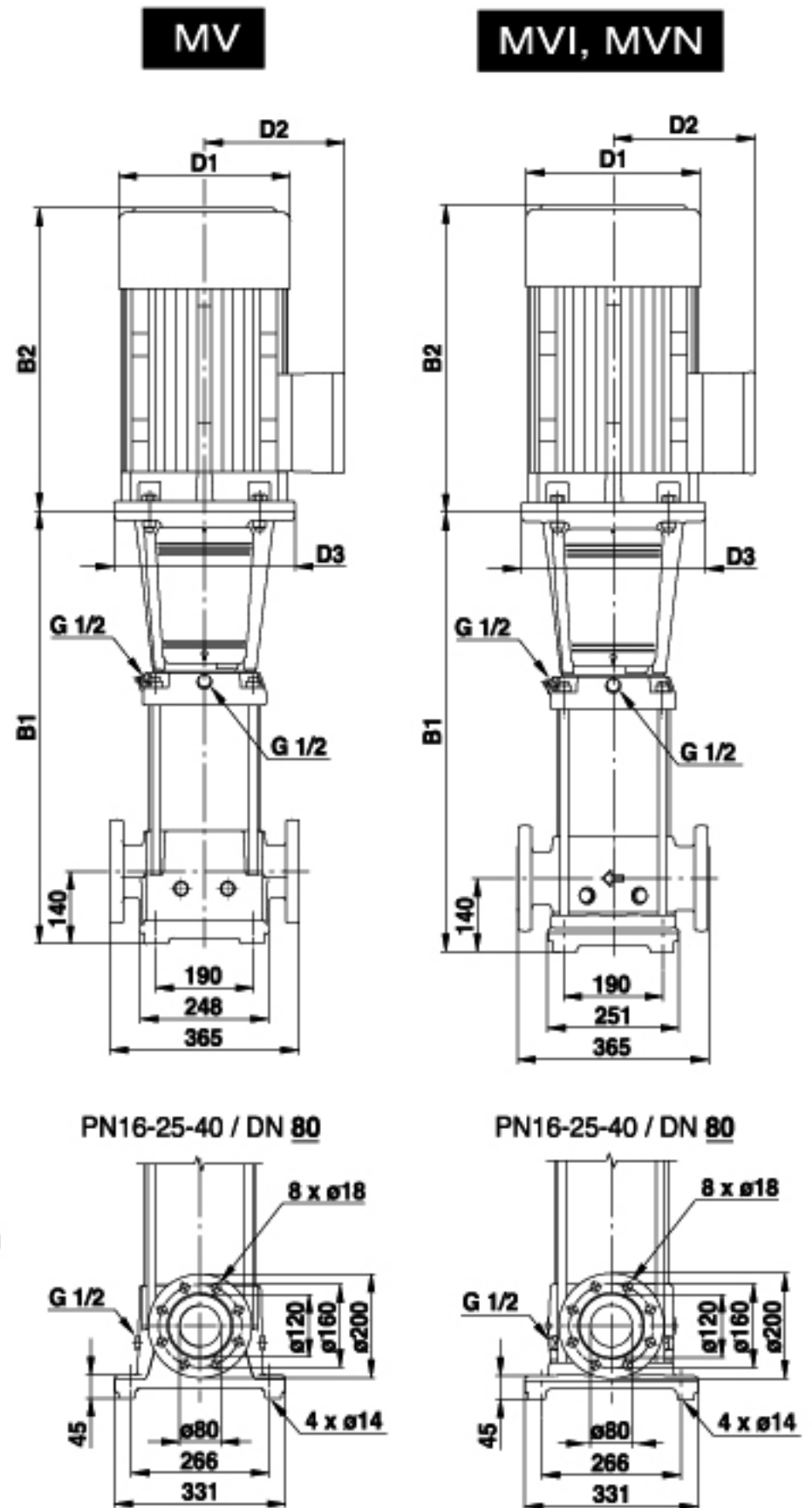
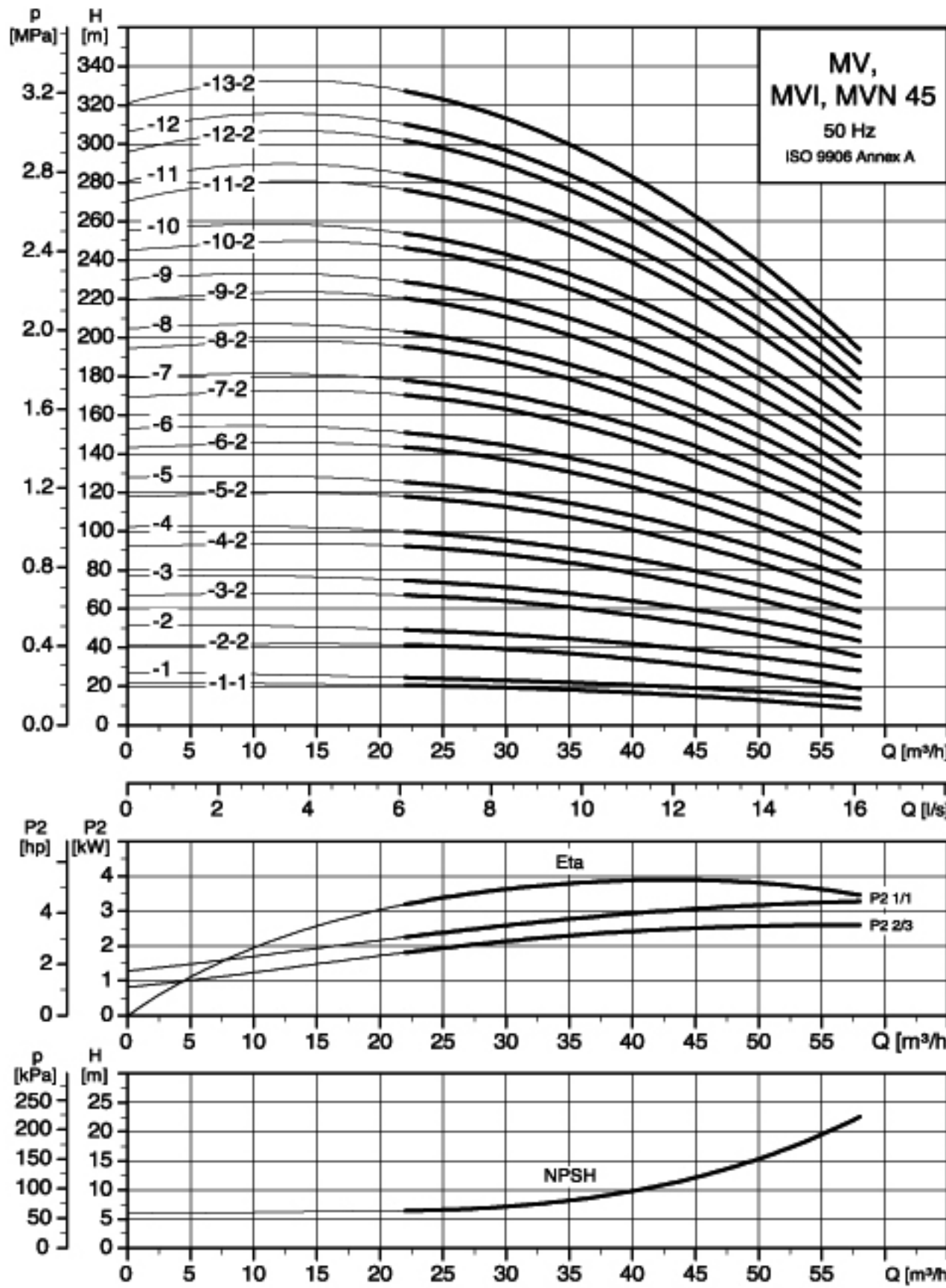
**Dimensions and weights**

Pump type	Motor P <sub>2</sub> [kW]	MV					Net weight [kg]	Pump type	Motor P <sub>2</sub> [kW]	MVI, MVN					Net weight [kg]
		B1	B1+B2	D1	D2	D3				B1	B1+B2	D1	D2	D3	
MV 32-1-1	1.5	505	786	178	110	135	61	MVI/MVN 32-1-1	1.5	505	786	178	110	135	61
MV 32-1	2.2	505	826	178	110	135	62	MVI/MVN 32-1	2.2	505	826	178	110	135	62
MV 32-2-2	3.0	575	910	198	120	-	76	MVI/MVN 32-2-2	3.0	575	910	198	120	-	76
MV 32-2	4.0	575	947	220	134	158	87	MVI/MVN 32-2	4.0	575	947	220	134	158	87
MV 32-3-2	5.5	645	1036	220	134	298	107	MVI/MVN 32-3-2	5.5	645	1036	220	134	298	107
MV 32-3	5.5	645	1036	220	134	298	107	MVI/MVN 32-3	5.5	645	1036	220	134	298	107
MV 32-4-2	7.5	715	1106	220	134	298	117	MVI/MVN 32-4-2	7.5	715	1106	220	134	298	117
MV 32-4	7.5	715	1106	220	134	298	117	MVI/MVN 32-4	7.5	715	1106	220	134	298	117
MV 32-5-2	11.0	895	1394	260	172	350	155	MVI/MVN 32-5-2	11.0	895	1394	260	172	350	155
MV 32-5	11.0	895	1394	260	172	350	155	MVI/MVN 32-5	11.0	895	1394	260	172	350	155
MV 32-6-2	11.0	965	1464	260	172	350	158	MVI/MVN 32-6-2	11.0	965	1464	260	172	350	158
MV 32-6	11.0	965	1464	260	172	350	158	MVI/MVN 32-6	11.0	965	1464	260	172	350	158
MV 32-7-2	15.0	1035	1513	320	197	350	175	MVI/MVN 32-7-2	15.0	1035	1513	320	197	350	175
MV 32-7	15.0	1035	1513	320	197	350	175	MVI/MVN 32-7	15.0	1035	1513	320	197	350	175
MV 32-8-2	15.0	1105	1583	320	197	350	178	MVI/MVN 32-8-2	15.0	1105	1583	320	197	350	178
MV 32-8	15.0	1105	1583	320	197	350	178	MVI/MVN 32-8	15.0	1105	1583	320	197	350	178
MV 32-9-2	18.5	1175	1693	320	197	350	211	MVI/MVN 32-9-2	18.5	1175	1693	320	197	350	211
MV 32-9	18.5	1175	1693	320	197	350	211	MVI/MVN 32-9	18.5	1175	1693	320	197	350	211
MV 32-10-2	18.5	1245	1763	320	197	350	214	MVI/MVN 32-10-2	18.5	1245	1763	320	197	350	214
MV 32-10	18.5	1245	1763	320	197	350	214	MVI/MVN 32-10	18.5	1245	1763	320	197	350	214
MV 32-11-2	22.0	1315	1925	363	262	350	250	MVI/MVN 32-11-2	22.0	1315	1925	363	262	350	250
MV 32-11	22.0	1315	1925	363	262	350	250	MVI/MVN 32-11	22.0	1315	1925	363	262	350	250
MV 32-12-2	22.0	1385	1995	363	262	350	254	MVI/MVN 32-12-2	22.0	1385	1995	363	262	350	254
MV 32-12	22.0	1385	1995	363	262	350	254	MVI/MVN 32-12	22.0	1385	1995	363	262	350	254
MV 32-13-2	30.0	1455	2101	415	300	400	322	MVI/MVN 32-13-2	30.0	1455	2101	415	300	400	322
MV 32-13	30.0	1455	2101	415	300	400	322	MVI/MVN 32-13	30.0	1455	2101	415	300	400	322
MV 32-14-2	30.0	1525	2171	415	300	400	325	MVI/MVN 32-14-2	30.0	1525	2171	415	300	400	325
MV 32-14	30.0	1525	2171	415	300	400	325	MVI/MVN 32-14	30.0	1525	2171	415	300	400	325

**Performance curves**

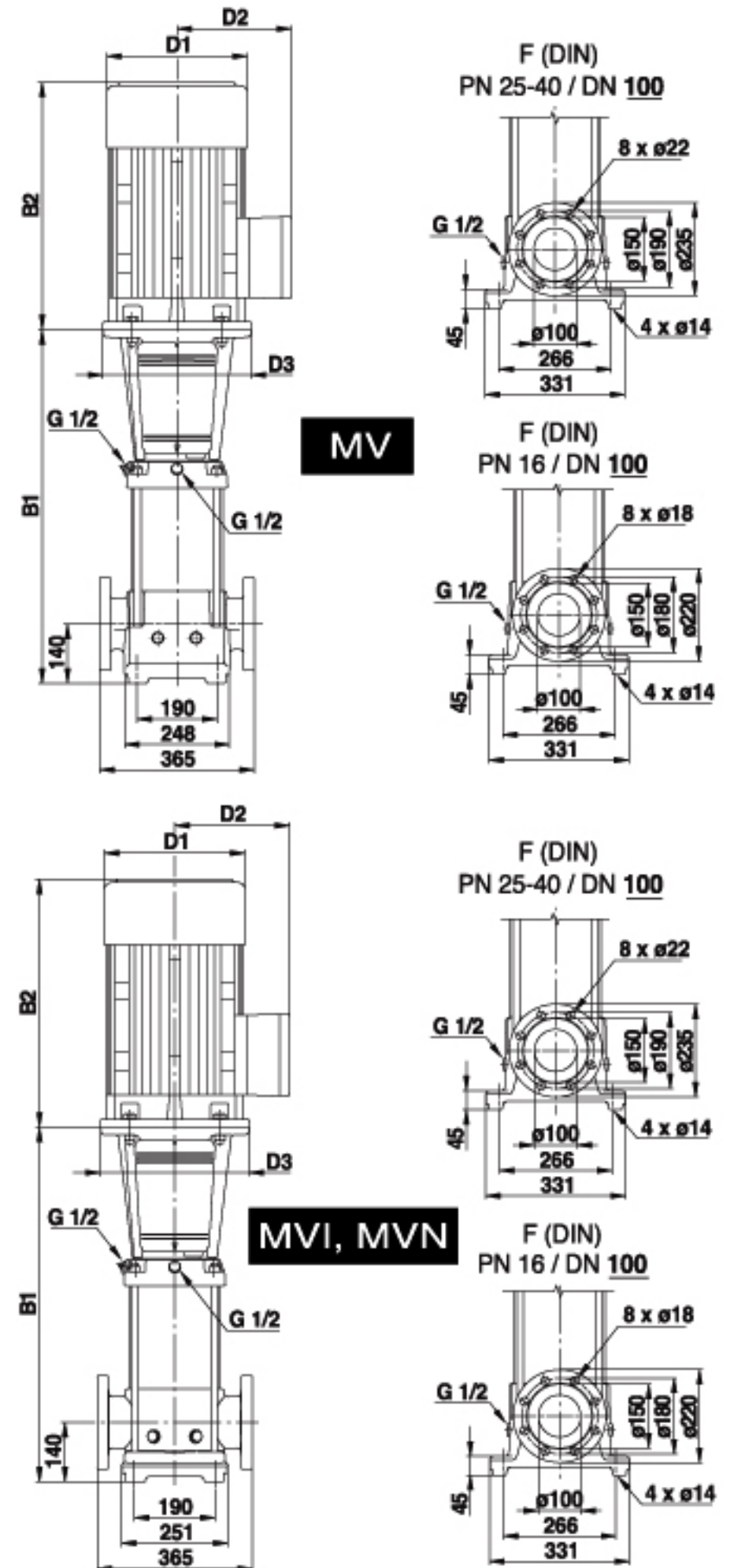
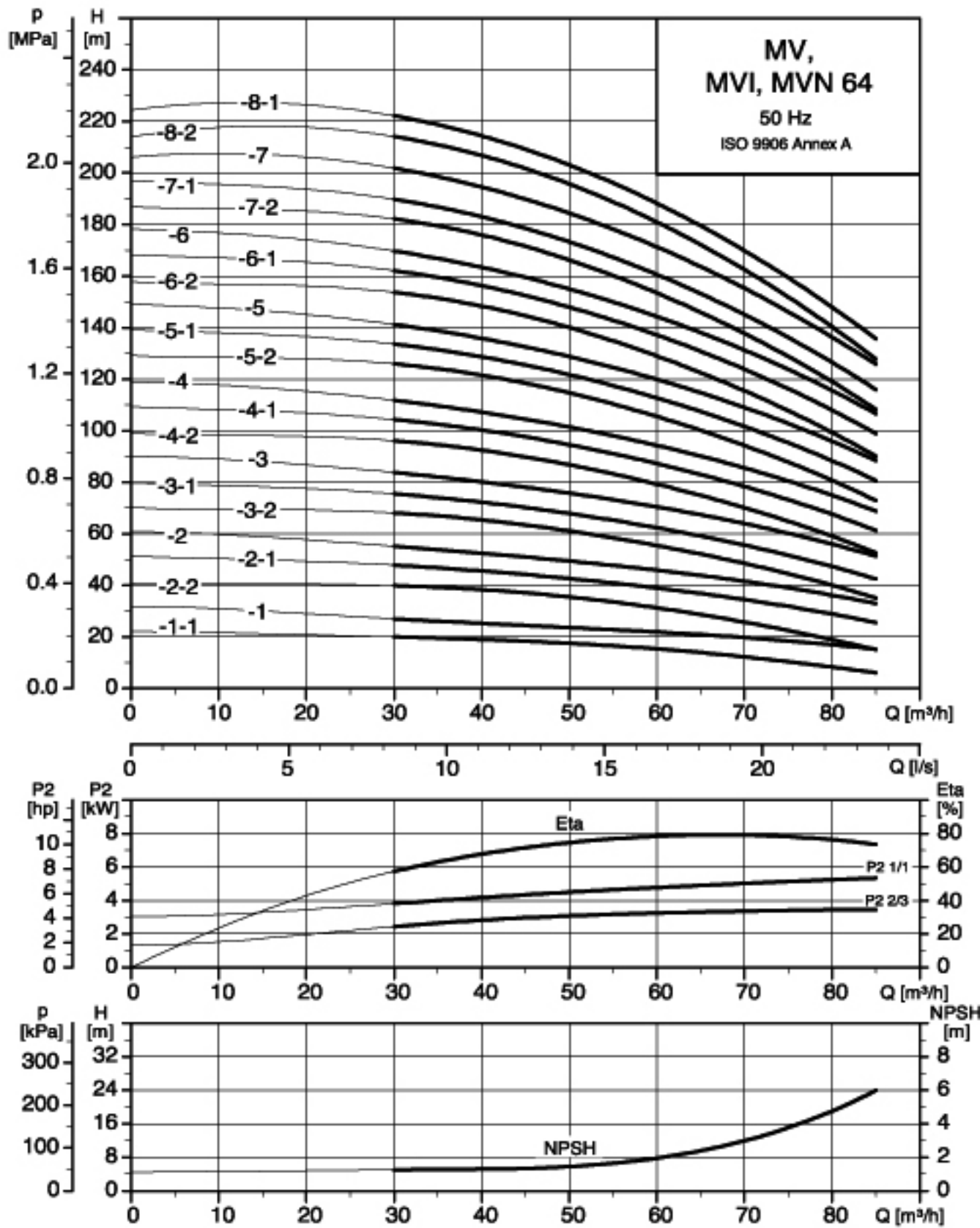
**Dimensions and weights**

Pump type	Motor P <sub>2</sub> [kW]	MV					Net weight [kg]	Pump type	Motor P <sub>2</sub> [kW]	MVI, MVN					Net weight [kg]
		B1	B1+B2	D1	D2	D3				B1	B1+B2	D1	D2	D3	
MV 45-1-1	3.0	559	894	198	120	-	80	MVI/MVN 45-1-1	3.0	559	894	198	120	-	80
MV 45-1	4.0	559	931	220	134	158	91	MVI/MVN 45-1	4.0	559	931	220	134	158	91
MV 45-2-2	5.5	639	1030	220	134	298	108	MVI/MVN 45-2-2	5.5	639	1030	220	134	298	108
MV 45-2	7.5	639	1030	220	134	298	110	MVI/MVN 45-2	7.5	639	1030	220	134	298	110
MV 45-3-2	11.0	829	1328	260	172	350	149	MVI/MVN 45-3-2	11.0	829	1328	260	172	350	149
MV 45-3	11.0	829	1328	260	172	350	149	MVI/MVN 45-3	11.0	829	1328	260	172	350	149
MV 45-4-2	15.0	909	1387	320	197	350	169	MVI/MVN 45-4-2	15.0	909	1387	320	197	350	169
MV 45-4	15.0	909	1387	320	197	350	169	MVI/MVN 45-4	15.0	909	1387	320	197	350	169
MV 45-5-2	18.5	989	1507	320	197	350	204	MVI/MVN 45-5-2	18.5	989	1507	320	197	350	204
MV 45-5	18.5	989	1507	320	197	350	204	MVI/MVN 45-5	18.5	989	1507	320	197	350	204
MV 45-6-2	22.0	1069	1679	363	262	350	240	MVI/MVN 45-6-2	22.0	1069	1679	363	262	350	240
MV 45-6	22.0	1069	1679	363	262	350	240	MVI/MVN 45-6	22.0	1069	1679	363	262	350	240
MV 45-7-2	30.0	1149	1795	415	300	400	321	MVI/MVN 45-7-2	30.0	1149	1795	415	300	400	321
MV 45-7	30.0	1149	1795	415	300	400	321	MVI/MVN 45-7	30.0	1149	1795	415	300	400	321
MV 45-8-2	30.0	1229	1875	415	300	400	336	MVI/MVN 45-8-2	30.0	1229	1875	415	300	400	336
MV 45-8	30.0	1229	1875	415	300	400	336	MVI/MVN 45-8	30.0	1229	1875	415	300	400	336
MV 45-9-2	30.0	1309	1955	415	300	400	341	MVI/MVN 45-9-2	30.0	1309	1955	415	300	400	341
MV 45-9	37.0	1309	2012	415	300	400	361	MVI/MVN 45-9	37.0	1309	2012	415	300	400	361
MV 45-10-2	37.0	1389	2092	415	300	400	366	MVI/MVN 45-10-2	37.0	1389	2092	415	300	400	366
MV 45-10	37.0	1389	2092	415	300	400	366	MVI/MVN 45-10	37.0	1389	2092	415	300	400	366
MV 45-11-2	45.0	1469	2178	442	325	450	478	MVI/MVN 45-11-2	45.0	1469	2178	442	325	450	478
MV 45-11	45.0	1469	2178	442	325	450	478	MVI/MVN 45-11	45.0	1469	2178	442	325	450	478
MV 45-12-2	45.0	1549	2258	442	325	450	483	MVI/MVN 45-12-2	45.0	1549	2258	442	325	450	483
MV 45-12	45.0	1549	2258	442	325	450	483	MVI/MVN 45-12	45.0	1549	2258	442	325	450	483
MV 45-13-2	45.0	1629	2338	442	325	450	488	MVI/MVN 45-13-2	45.0	1629	2338	442	325	450	488

**Performance curves**

**Dimensions and weights**

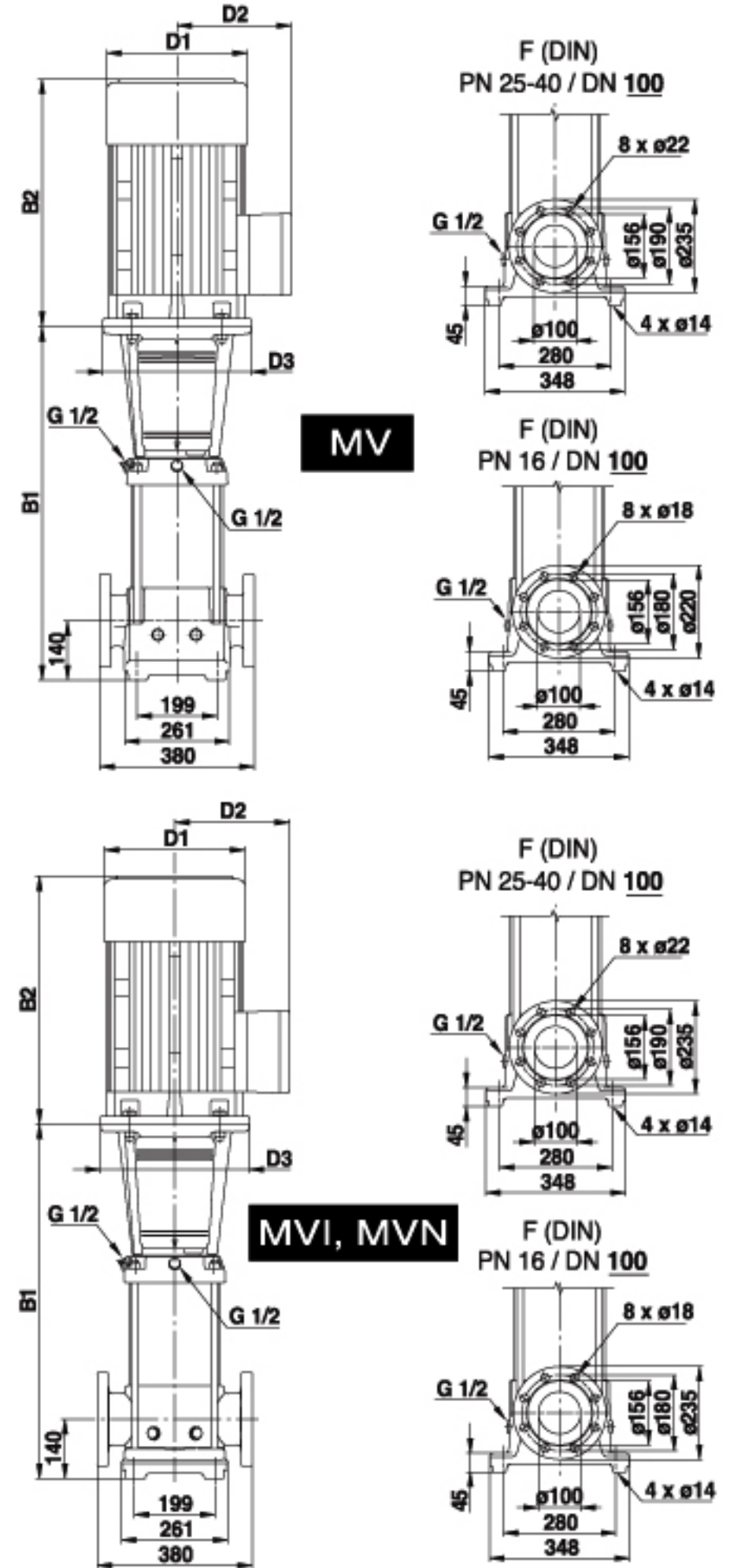
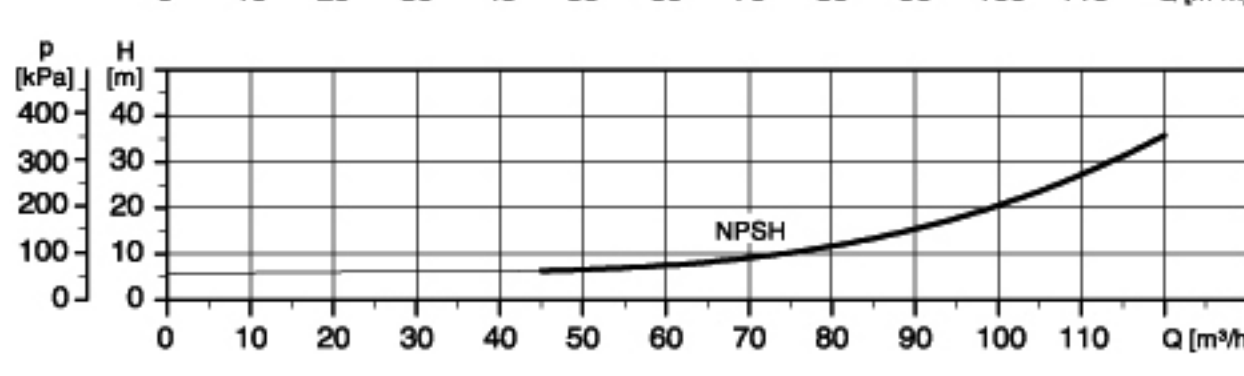
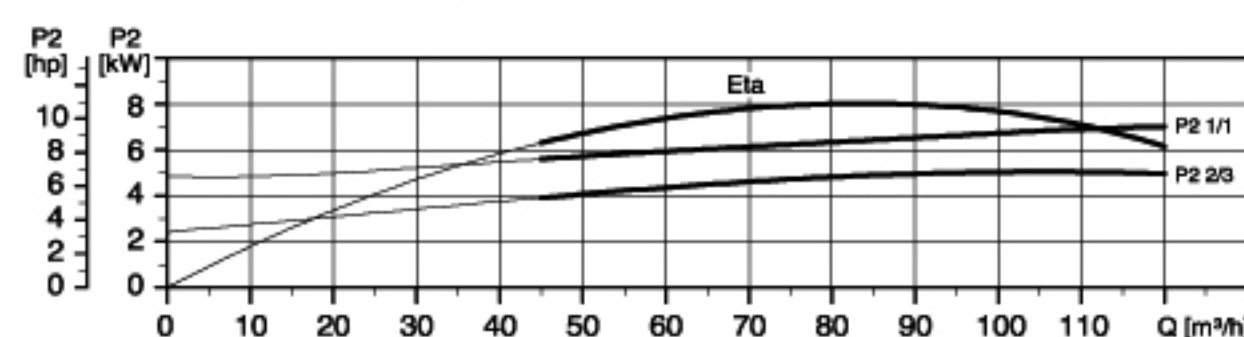
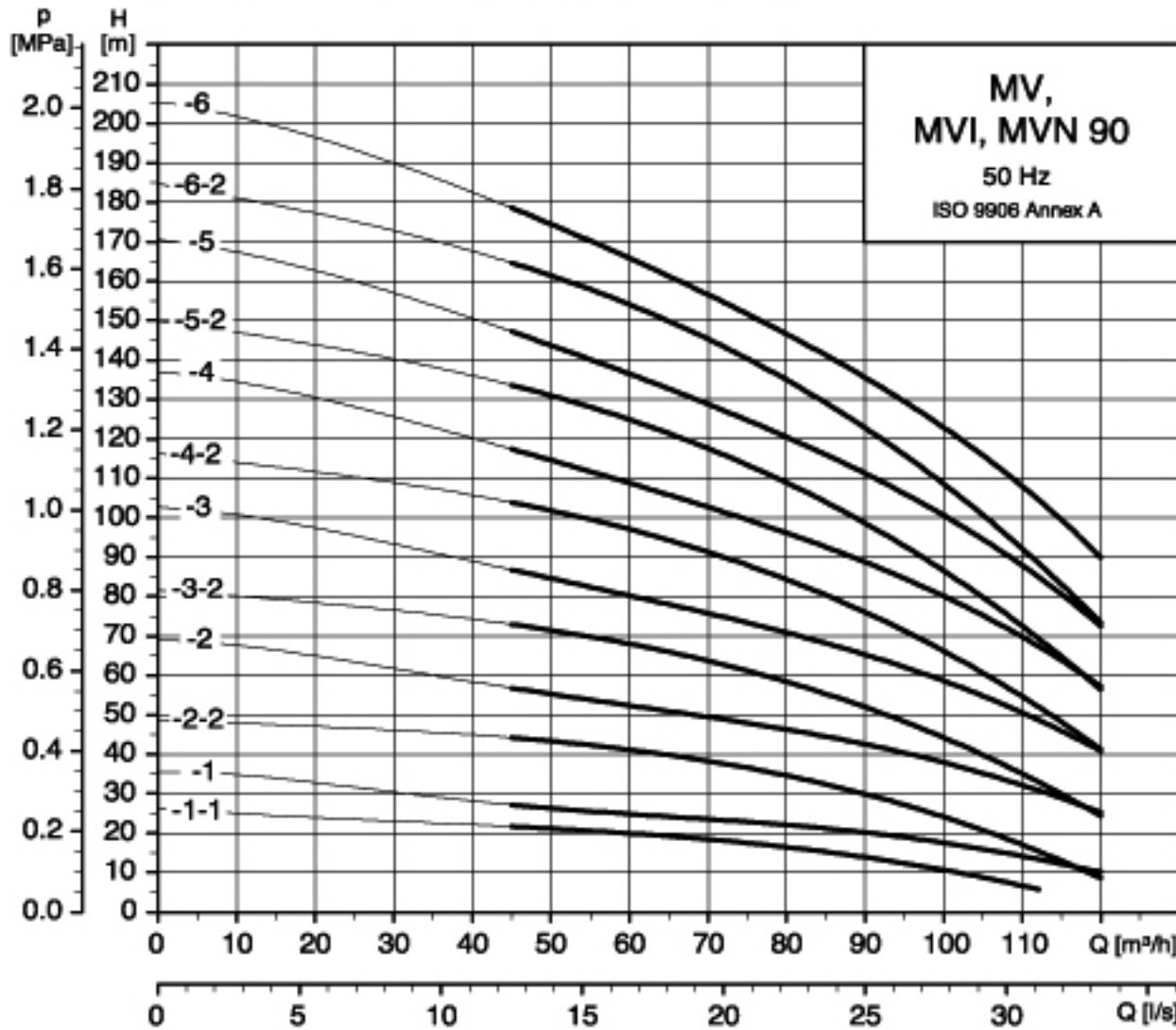
Pump type	Motor P <sub>2</sub> [kW]	MV					Net weight [kg]
		Dimension [mm]					
		B1	B1+B2	D1	D2	D3	
MV 64-1-1	4.0	561	933	220	134	158	91
MV 64-1	5.5	561	952	220	134	298	102
MV 64-2-2	7.5	644	1035	220	134	298	114
MV 64-2-1	11.0	754	1253	260	172	350	149
MV 64-2	11.0	754	1253	260	172	350	149
MV 64-3-2	15.0	836	1314	320	197	350	174
MV 64-3-1	15.0	836	1314	320	197	350	174
MV 64-3	18.5	836	1354	320	197	350	204
MV 64-4-2	18.5	919	1437	320	197	350	214
MV 64-4-1	22.0	919	1529	363	262	350	245
MV 64-4	22.0	919	1529	363	262	350	245
MV 64-5-2	30.0	1001	1647	415	300	400	316
MV 64-5-1	30.0	1001	1647	415	300	400	316
MV 64-5	30.0	1001	1647	415	300	400	316
MV 64-6-2	30.0	1084	1730	415	300	400	336
MV 64-6-1	37.0	1084	1787	415	300	400	356
MV 64-6	37.0	1084	1787	415	300	400	356
MV 64-7-2	37.0	1166	1869	415	300	400	376
MV 64-7-1	37.0	1166	1869	415	300	400	376
MV 64-7	45.0	1166	1875	442	325	450	440
MV 64-8-2	45.0	1249	1958	442	325	450	473
MV 64-8-1	45.0	1249	1958	442	325	450	473

Pump type	Motor P <sub>2</sub> [kW]	MVI, MVN					Net weight [kg]
		Dimension [mm]					
		B1	B1+B2	D1	D2	D3	
MVI/MVN 64-1-1	4.0	561	933	220	134	158	91
MVI/MVN 64-1	5.5	561	952	220	134	298	102
MVI/MVN 64-2-2	7.5	644	1035	220	134	298	114
MVI/MVN 64-2-1	11.0	754	1253	260	172	350	149
MVI/MVN 64-2	11.0	754	1253	260	172	350	149
MVI/MVN 64-3-2	15.0	836	1314	320	197	350	174
MVI/MVN 64-3-1	15.0	836	1314	320	197	350	174
MVI/MVN 64-3	18.5	836	1354	320	197	350	204
MVI/MVN 64-4-2	18.5	919	1437	320	197	350	214
MVI/MVN 64-4-1	22.0	919	1529	363	262	350	245
MVI/MVN 64-4	22.0	919	1529	363	262	350	245
MVI/MVN 64-5-2	30.0	1001	1647	415	300	400	316
MVI/MVN 64-5-1	30.0	1001	1647	415	300	400	316
MVI/MVN 64-5	30.0	1001	1647	415	300	400	316
MVI/MVN 64-6-2	30.0	1084	1730	415	300	400	336
MVI/MVN 64-6-1	37.0	1084	1787	415	300	400	356
MVI/MVN 64-6	37.0	1084	1787	415	300	400	356
MVI/MVN 64-7-2	37.0	1166	1869	415	300	400	376
MVI/MVN 64-7-1	37.0	1166	1869	415	300	400	376
MVI/MVN 64-7	45.0	1166	1875	442	325	450	440
MVI/MVN 64-8-2	45.0	1249	1958	442	325	450	473
MVI/MVN 64-8-1	45.0	1249	1958	442	325	450	473

**Performance curves**

**Dimensions and weights**

Pump type	Motor P <sub>2</sub> [kW]	MV					Net weight [kg]
		Dimension [mm]					
		B1	B1+B2	D1	D2	D3	
MV 90-1-1	5.5	571	962	220	134	298	107
MV 90-1	7.5	571	962	220	134	298	109
MV 90-2-2	11.0	773	1272	260	172	350	150
MV 90-2	15.0	773	1251	320	197	350	164
MV 90-3-2	18.5	865	1383	320	197	350	214
MV 90-3	22.0	865	1475	363	262	350	245
MV 90-4-2	30.0	957	1603	415	300	400	326
MV 90-4	30.0	957	1603	415	300	400	326
MV 90-5-2	37.0	1049	1752	415	300	400	366
MV 90-5	37.0	1049	1752	415	300	400	366
MV 90-6-2	45.0	1141	1850	442	325	450	437
MV 90-6	45.0	1141	1850	442	325	450	437

Pump type	Motor P <sub>2</sub> [kW]	MVI, MVN					Net weight [kg]
		Dimension [mm]					
		B1	B1+B2	D1	D2	D3	
MVI/MVN 90-1-1	5.5	571	962	220	134	298	107
MVI/MVN 90-1	7.5	571	962	220	134	298	109
MVI/MVN 90-2-2	11.0	773	1272	260	172	350	150
MVI/MVN 90-2	15.0	773	1251	320	197	350	164
MVI/MVN 90-3-2	18.5	865	1383	320	197	350	214
MVI/MVN 90-3	22.0	865	1475	363	262	350	245
MVI/MVN 90-4-2	30.0	957	1603	415	300	400	326
MVI/MVN 90-4	30.0	957	1603	415	300	400	326
MVI/MVN 90-5-2	37.0	1049	1752	415	300	400	366
MVI/MVN 90-5	37.0	1049	1752	415	300	400	366
MVI/MVN 90-6-2	45.0	1141	1850	442	325	450	437
MVI/MVN 90-6	45.0	1141	1850	442	325	450	437

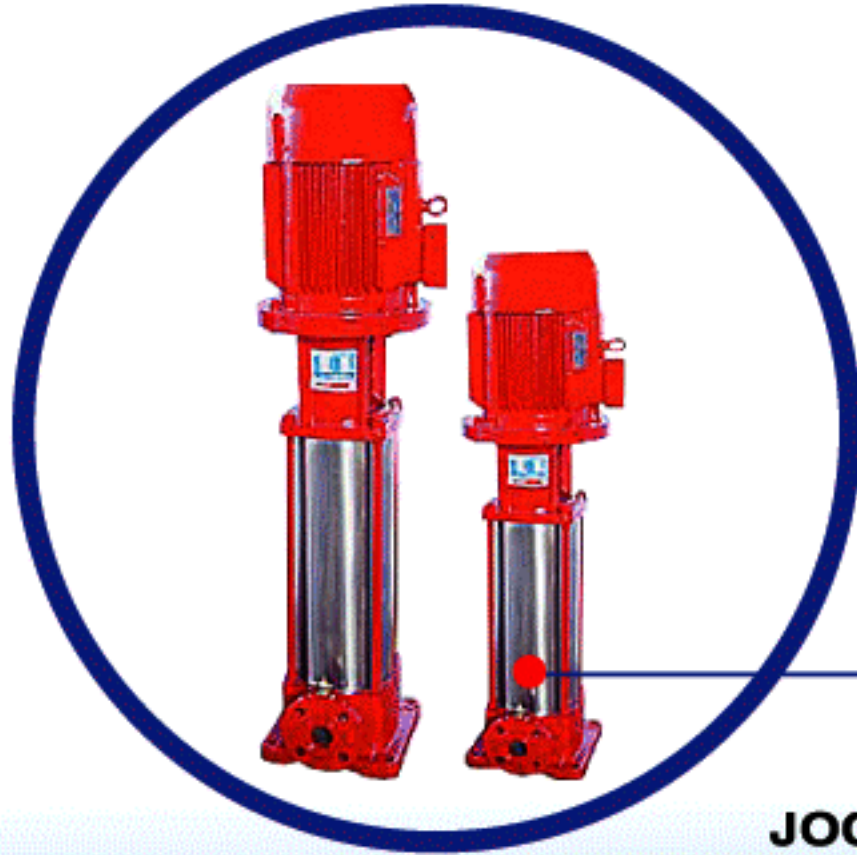
# MV, MVI, MVN SERIES



**JOCKEY PUMP IN  
FIRE PUMP PACKAGE SYSTEM**

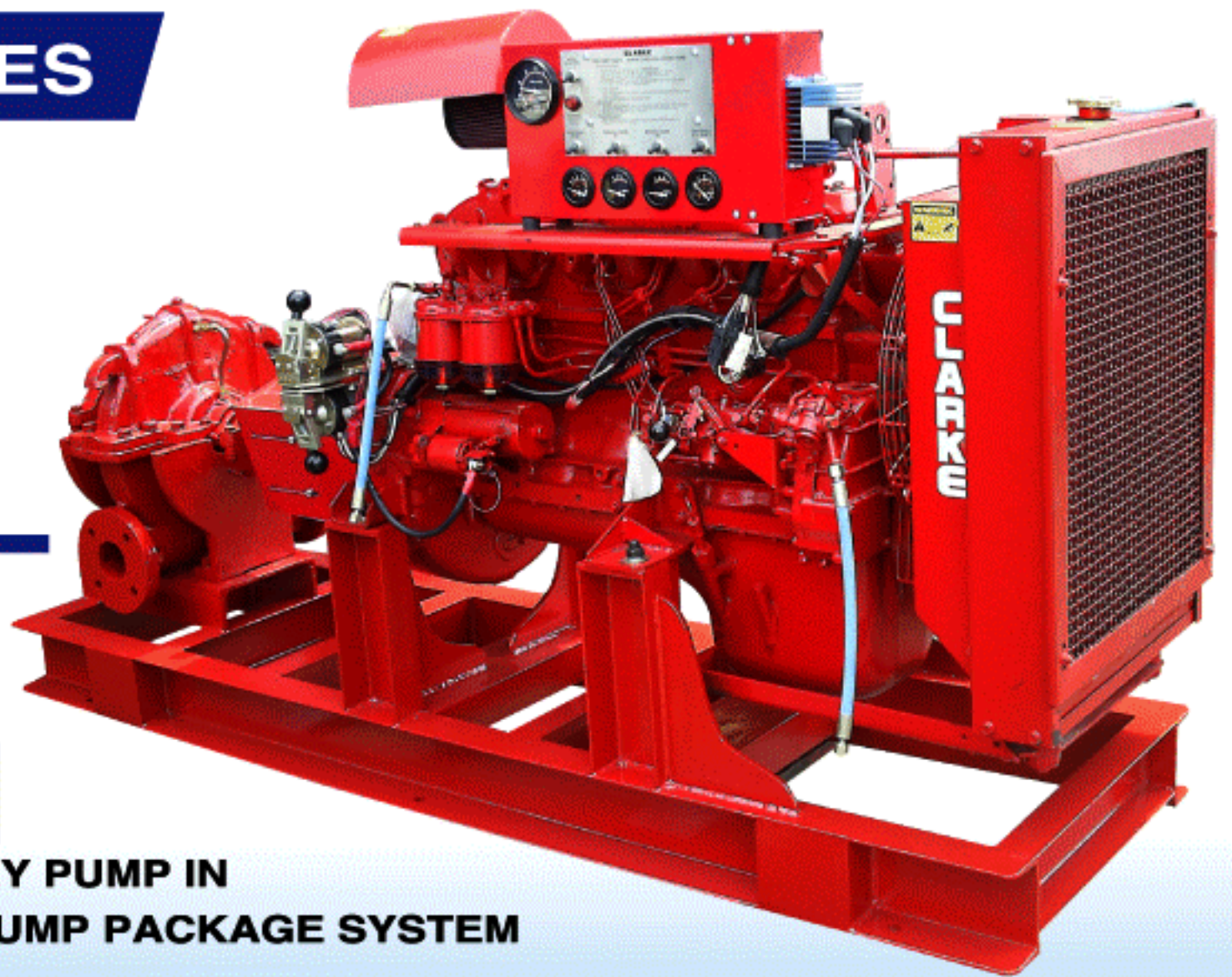

**WATER TREATMENT,  
REVERSE OSMOSIS  
SYSTEM**



**WATER SUPPLY AND  
PRESSURE BOOSTING**



**MVN SERIES**



**MASTERFLOW**

**MV**

Stainless steel vertical  
multistage centrifugal pump

